



# *USER INSTRUCTIONS*

## ***MaxFlo 4 NR***

Diaphragm Rotary Actuator

FCD VLENIM0065-01 A4 03/17

***Installation  
Operation  
Maintenance***



# Diaphragm Rotary Actuator - MaxFlo 4 NR

Diaphragm actuators take the form of a flexible diaphragm, placed between two casings. The upper section of the two chambers is designed pressure tight, the lower chamber holds a spring opposing the force generated within the pressure chamber of actuator. The controlled air supply is connected to the pressure tight chamber, and an increase or decrease of the air pressure results in a positioning force of the stem. This kind of actuator is called single acting with spring return positioning force converted by a lever from a linear motion to a rotary motion. The rotation angle is limited to 60 degrees. The lever is installed and guided in a case, called transfer case. The transfer case is designed so that the actuator can be mounted in two positions, thus allowing two fail safe positions, close or open. Simplicity of design reduces maintenance and parts inventory costs. It is ideally suited for flow and pressure control of liquid and gas media in oil and gas, power, chemical and petrochemical processing and related industries. The MaxFlo 4 NR is manufactured to ISO 9001 standards.

The following instructions are designed to assist in unpacking, installing and performing maintenance as required on Flowserve MaxFlo 4 NR diaphragm rotary actuators. This instruction manual does not include specific product design data. Such data can be found on the actuator's serial plate or specification documents; additionally, dimensional information can be found in the MaxFlo 4 NR technical bulletin. Procure needed documents as necessary before you begin any work on the valve.

User Instructions cannot deal with all possible situations and installation options. It is required that only trained and qualified technicians are authorized to adjust, repair or work on diaphragm rotary actuators, positioners and other accessories. Review this bulletin prior to installing, operating or performing any maintenance on the actuator. Additional Installation, Operation, and Maintenance Instructions (IOMs) cover other features (such as positioners and other accessories).

To avoid possible injury to personnel or damage to actuator parts, WARNING and NOTICE indicators must be strictly followed. Modifying this product, substituting non-factory parts or using maintenance procedures other than outlined could drastically affect performance and be hazardous to personnel and equipment and may void existing warranties. This manual should be used in conjunction with applicable local and national laws. Failure to comply with User Instructions will render the manufacturer's guarantee and liability null and void. Unless otherwise agreed, the manufacturer's general terms and conditions of sale shall apply.

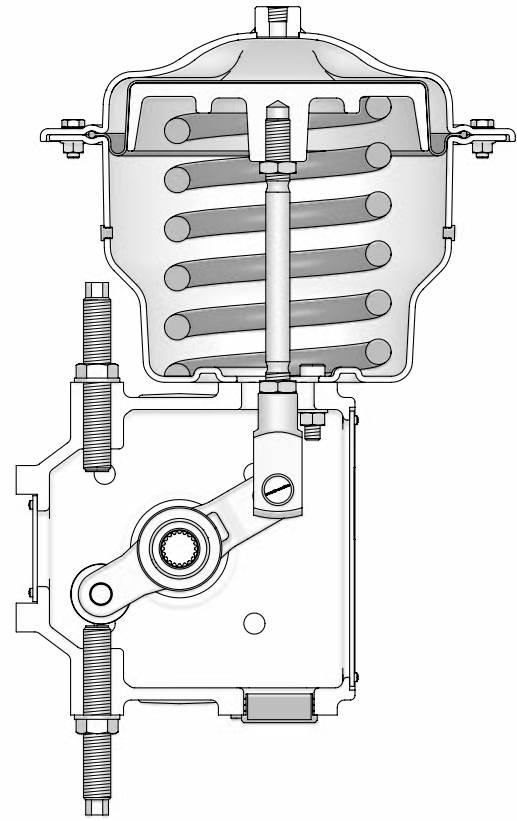

Figure 1: MaxFlo 4 NR - Actuator

**Read the user instructions carefully before use.  
Keep for future reference.**

## Contents

1	Scope of Manual	3	7	Storage	4	13	Troubleshooting	11 - 12
2	Intended Use	3	8	Unpacking	4 - 5	14	Disassembly and Reassembly	12 - 15
3	Product Identification	3	9	Installation	5 - 6	15	Torque Requirements	16
4	Modification	3 - 4	10	Assembly on valve	7 - 9	16	Lubricants	16
5	Safety	4	11	Actuator Quick-Check	9 - 10	17	Disposal	17
6	Packaging and Transport	4	12	Actuator Maintenance	10 - 11	18	Parts List	18 - 19

# 1 Scope of Manual

The following user information covers the MaxFlo 4 NR diaphragm rotary actuator:

- for MaxFlo 4 valves only
- Metric DIN Units      Size 1S for DN    25 - 50  
                                  Size 2S for DN    80 - 100  
                                  Size 3S for DN    150 - 300
- English ASME Units    Size 1S for NPS    1 - 2  
                                  Size 2S for NPS    3 - 4  
                                  Size 3S for NPS    6 - 12
- Comes with or without ancillary equipment

# 2 Intended Use

**WARNING** Diaphragm rotary actuators are pressure vessels designed and rated for specific application conditions. Before installation, check the serial number and / or the tag number to ensure that the valve and actuator being installed are correct for the intended application. Do not use the valve assembly outside of its rated design limits. Exceeding the design limits may cause hazardous conditions including leakage of the process media or rupture of the pressure boundary resulting in possible process loss, equipment or environmental damage, or serious personal injury or death.

The specific product design data can be found on the actuators's serial plate, data sheet and the calculation sheet (in acc. to the IEC 60534-7:2010).

The MaxFlo 4 NR handles a wide variety of general service applications.

The MaxFlo 4 NR consists of the actuator, transfer case, yoke and connecting parts. The actuator is designed with a high level of interchangeability allowing the user to assemble the greatest possible number of variations from a minimum number of components to match each application. There are two fail safe positions, close or open without or with handwheel.

The MaxFlo 4 NR is designed in compliance with **EN 1349:2009** - Industrial Process Control Valves (DIN EN 1349 and VDE 0409-1349).

The MaxFlo 4 NR actuator is designed for use in **MODERATE**

and **WORLDWIDE** environmental conditions, ambient temperature range -76°F to 158°F (-60°C to +70°C), air humidity up to 93% non-condensing, air pollution up to 300 µg/m<sup>3</sup>, unless restricted by the accessories.

The product offering may include optional ancillary equipment, such as positioners, air-filter regulators, solenoid valves, limit switches or boosters. Digital, I/P, or pneumatic positioners can be mounted with a mounting bracket. Refer to the relevant manufacturer's user instructions for information regarding other ancillary equipment.

# 3 Product Identification

Each MaxFlo 4 NR diaphragm rotary actuator comes with an attached serial plate which includes key information specifically for each actuator:

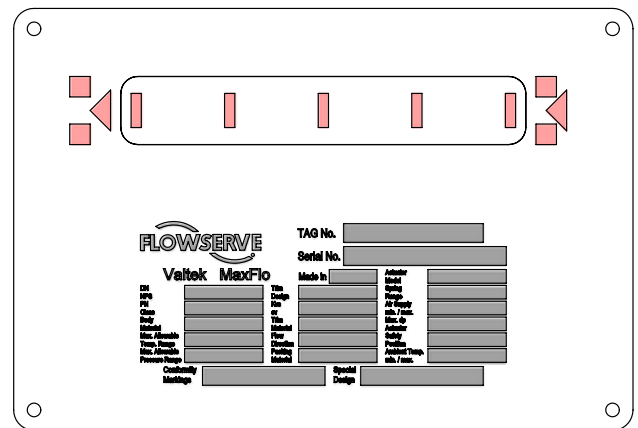

Figure 2: Serial Plate

The same serial number shown on the plate will appear on all MaxFlo 4 NR data sheets, dimensional drawings, bills of material, and spare parts lists. Other information located on the serial plate is self-explanatory for the MaxFlo 4 NR actuator.

You can download .pdf versions of the MaxFlo 4 NR documentation including a sales brochure, technical bulletin and user instructions at [www.flowserve.com](http://www.flowserve.com). It is the user's responsibility to keep this and related documentation on file and accessible for the MaxFlo 4 NR product.

# 4 MaxFlo 4 NR Modification

MaxFlo 4 NR rotary actuators are generally delivered as tested and assembled units.

**Unauthorized modification of the MaxFlo 4 NR diaphragm rotary actuator voids the product test certification and product warranties, could drastically affect product performance, and could be hazardous to personnel and equipment.**

**NOTICE** Before MaxFlo 4 NR re-use, all necessary tests must be repeated and recorded in compliance with all test routines, guidelines and engineering standards.

## 5 Safety

Safety terms - WARNING and NOTICE - are used to highlight specific dangers and / or provide additional information that may not be readily apparent in the User Instructions. WARNING directions must be strictly followed.

**WARNING** or **WARNING** indicates that severe personal injury, death and substantial property damage can occur if proper precautions are not taken.

**NOTICE** NOTICE indicates practices or provides additional technical information.

Grey fields indicate safety-related informations.

## 6 Packaging and Transport

**Pay close attention to shipping marks and transport pictograms.**

Careful packing, loading and transport arrangements are required to prevent products from being damaged during transport. Standard packaging includes a cardboard box, with or without a wooden pallet base as needed. Special packaging may include a wooden box. Packaging may use cardboard, plastic wrap, foam, or paper as packing material. Filling material may be a carton type or paper.

Shipping marks display product and package dimensions and weight (for further information see Packaging and Sending Instructions, Form L 002). Packing guidelines for export

follow HPE standards. (Nonreturnable packaging may contain up to 90% recyclable materials.)

## 7 Storage

**Maximum storage time for diaphragm rotary actuators is 2 years at 25 °C.**

**NOTICE** Rubber become brittle, lubricants become resinous, see also ISO 2230.

Upon arrival on site, store the MaxFlo 4 NR actuator on a solid base in a cool, dry closed room. Until its installation, the actuator must be protected from the weather, dirt and other potentially harmful influences.

Do not remove the protective covers from the air supply connection of the actuator or from the instrument and accessories until the actuator is ready for installation at the site.

## 8 Unpacking

**Hoisting and lifting are inherently dangerous activities and require safe rigging and proper training to mitigate hazards. Use standard industry safety practices, personal protection, and warranted lifting devices.**

**WARNING** Crushing hazard ! Arrange rigging to prevent tipping of the actuator. Do not allow the actuator assembly to rotate during removal. Do not stand under suspended loads. Failure to do so can cause serious personal injury and damage the actuator or nearby equipment.

**NOTICE** Be aware that the center of gravity may be above the lifting point. Do not allow the sling to touch the stem, travel indicator or peripheral equipment. Observe the maximum permitted carrying capacity.

1. Check the packing list against materials received to ensure all components and accessories are present.
2. Place a sling around the actuator case just above the transfer case.

3. You can alternatively hook a double-leg sling into the lifting rings mounted on the actuator.

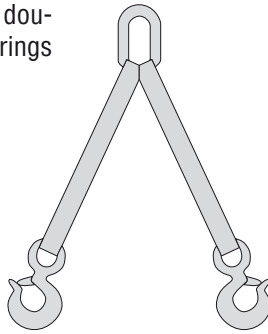

Figure 3: Double-leg sling

4. Upon removing the actuator from the packaging, we recommend that you:

- Promptly touch up any damage to the corrosion protection.
- Contact your shipper immediately to report any damage.
- Call your Flowserve representative if you experience any problems.
- Do not remove the protective covers from the air supply connection of the actuator or from the instrument ports of the actuator and accessories until the actuator is ready for installation at the site.

## 9 Installation

The actuator must be installed and commissioned by qualified staff - personnel who are familiar with the installation, commissioning and operation of this product and possess the relevant qualifications in their field of activity.



Prior to installation of the actuator, we require, that you check the following conditions to reduce the risk of malfunction and safety related incidents.

No.	Check	Possible malfunction or safety related incident																
1	Confirm that the nominal / operational data on the serial plate matches the operational data of the facility.	An operational mismatch can cause considerable damage to the actuator or may lead to a failure at the facility.																
2	Confirm that the air supply and instrument signal lines are dry and clear of dirt and oil.	At a minimum, the instrument air must conform to ISA- 7.0.01-1996 (ISO 8573-1 Compressed Air - Class 2) requirement or those of the accessory manufacturer.																
3	Confirm that the actuator can be installed in an upright position the valve with horizontal shaft whenever possible.	Non-upright positioning may result in premature wear.																
4	Confirm that a suitable yoke for attachment to the valve and all coupling parts are present.	Flange connection of rotary actuators based on ISO 5211-2001 <table border="1" data-bbox="821 1809 1476 1966"> <thead> <tr> <th>Actuator Size</th> <th>Flange connection</th> <th>Centering</th> <th>Shaft diameter</th> </tr> </thead> <tbody> <tr> <td>1S</td> <td>F10</td> <td>Y</td> <td>0.62 inch</td> </tr> <tr> <td>2S</td> <td>F14</td> <td>Y</td> <td>0.88 inch</td> </tr> <tr> <td>3S</td> <td>F16</td> <td>Y</td> <td>1.45 inch</td> </tr> </tbody> </table>	Actuator Size	Flange connection	Centering	Shaft diameter	1S	F10	Y	0.62 inch	2S	F14	Y	0.88 inch	3S	F16	Y	1.45 inch
Actuator Size	Flange connection	Centering	Shaft diameter															
1S	F10	Y	0.62 inch															
2S	F14	Y	0.88 inch															
3S	F16	Y	1.45 inch															

Table 1: Basic safety messages for installing the actuator (continued on next page 6)

No.	Check	Possible malfunction or safety related incident																																		
5	Confirm that the valve shaft and actuator lever match.	<p><i>Rotational connection between actuator lever and valve shaft according to ANSI B92.1-1996 internal involute spline</i></p> <table border="1"> <thead> <tr> <th>Actuator Size</th> <th>Number of Teeth</th> <th>Pitch</th> <th>Angle</th> </tr> </thead> <tbody> <tr> <td>1S</td> <td>12</td> <td>20/40</td> <td>30°</td> </tr> <tr> <td>2S</td> <td>20</td> <td>24/48</td> <td>30°</td> </tr> <tr> <td>3S</td> <td>28</td> <td>20/40</td> <td>30°</td> </tr> </tbody> </table>	Actuator Size	Number of Teeth	Pitch	Angle	1S	12	20/40	30°	2S	20	24/48	30°	3S	28	20/40	30°																		
Actuator Size	Number of Teeth	Pitch	Angle																																	
1S	12	20/40	30°																																	
2S	20	24/48	30°																																	
3S	28	20/40	30°																																	
6	Confirm the actuator has enough overhead clearance to disassemble the valve from the pipeline.	<p><i>Figure 4: Overhead clearance drawing</i></p> <table border="1"> <thead> <tr> <th rowspan="2">Actuator Code</th> <th colspan="2">Removal Space</th> <th colspan="2">~ R</th> <th colspan="2">≈ C Centerline Pipe to Actuator</th> </tr> <tr> <th>mm</th> <th>inch</th> <th>mm</th> <th>inch</th> <th>mm</th> <th>inch</th> </tr> </thead> <tbody> <tr> <td>1S</td> <td>200</td> <td>7.1</td> <td>260</td> <td>10.2</td> <td>330</td> <td>13.0</td> </tr> <tr> <td>2S</td> <td>250</td> <td>7.9</td> <td>290</td> <td>11.4</td> <td>400</td> <td>15.7</td> </tr> <tr> <td>3S</td> <td>300</td> <td>11.8</td> <td>330</td> <td>13.0</td> <td>565</td> <td>22.2</td> </tr> </tbody> </table> <p><i>Table 2: Overhead clearance dimensions</i></p>	Actuator Code	Removal Space		~ R		≈ C Centerline Pipe to Actuator		mm	inch	mm	inch	mm	inch	1S	200	7.1	260	10.2	330	13.0	2S	250	7.9	290	11.4	400	15.7	3S	300	11.8	330	13.0	565	22.2
Actuator Code	Removal Space			~ R		≈ C Centerline Pipe to Actuator																														
	mm	inch	mm	inch	mm	inch																														
1S	200	7.1	260	10.2	330	13.0																														
2S	250	7.9	290	11.4	400	15.7																														
3S	300	11.8	330	13.0	565	22.2																														
7	Confirm removal of all hazards and ensure appropriate protective measures are in place.	<i>none</i>																																		
8	Confirm the valve is grounded in order to prevent an electrical discharge.	<i>Noncompliance may result in electrical discharges.</i>																																		
9	Throttling control valves are typically equipped with a pneumatic actuator and valve positioner. Refer to the appropriate positioner manual for connections and maximum air supplies.	<i>The air supply must be limited to less than 88 psig (6 bar) per the actuator serial plate. An air filter regulator should be installed to ensure that the supply pressure to the pneumatic actuator does not exceed the air supply pressure indicated on the serial plate.</i>																																		

Table 1: Basic safety messages for installing the actuator

After these requirements are confirmed the actuator can be installed and connected to the valve.



# 10 Assembly on valve

**The MaxFlo 4 NR diaphragm rotary actuator is allowed to be assembled and reassembled only by qualified staff - personnel who are familiar with assembling, reassembling, installation and commissioning of this product, and possess the relevant qualifications in their field of activity.**

When performing repairs, personnel are to follow these instructions using only **original** equipment manufacturer (OEM) spare parts and recommended special tools to ensure the reliability of the MaxFlo 4 NR diaphragm rotary actuator.

Only Flowserve trained and authorized personnel are allowed to repair (disassemble and reassemble) the MaxFlo 4 NR in hazard areas.

Actuators for oil and grease-less service or oxygen service may only be disassembled and reassembled in clean rooms (ISO 14644- ISO 8, US FED STD 209 E - M 6.5, or equivalent).

**WARNING** Diaphragm rotary actuators are pressure vessels. Improper opening of the actuator can result in bodily injury.

## Actuator assembly procedure

1. Fix the valve on the assembly table.

**NOTICE** *The orientation of the valve must be in accordance with the mounting orientations !*

2. Lubricate all threads with a suitable, approved lubricant. (See Section 16)
3. Mount the yoke (201), washer (112) and head hex bolts (107) onto the valve bonnet.
4. Finger tighten and fix the valve bolts clockwise. (See Section 15)
5. Lubricate all threads with a suitable, approved lubricant. (See Section 16)
6. Rotate the shaft out of the seat by about 30 ° (center)
7. Place the two piece clamp onto the shaft.
8. Connect the air supply and move the actuator to the center position (see plate).
9. Mount the actuator so that the marking match between the shaft and lever.
10. Tighten the head hex bolts (336) clockwise. (See Section 15)

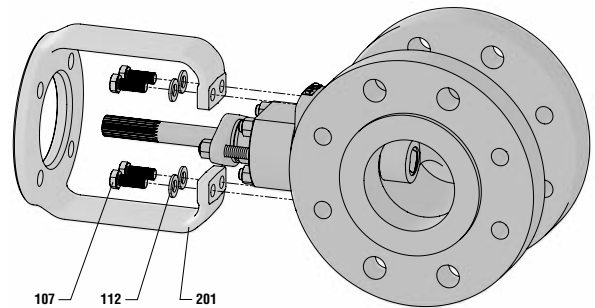

Figure 5: Yoke assembly drawing

Item	Part
107	Hex Head Bolt
112	Flat Washer

Item	Part
201	Yoke

Table 2: Coupling parts identification

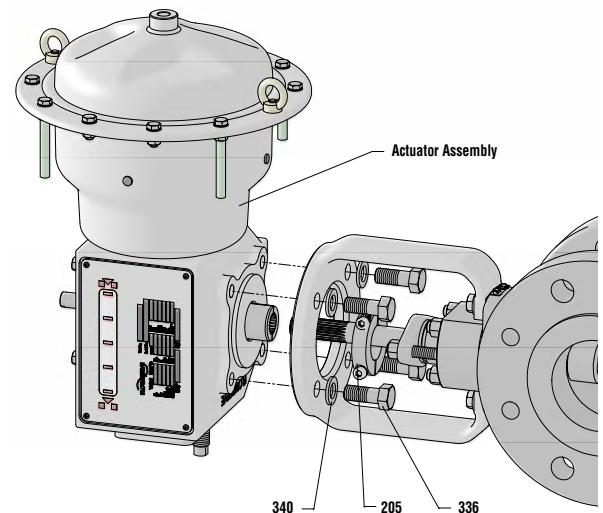

Figure 6: Actuator assembly drawing

Item	Part
205	Two Piece Clamp
336	Hex Head Bolt

Item	Part
340	Flat Washer

Table 3: Coupling parts identification

11. Lower the two piece clamp (205) onto the lever.

**NOTICE** *The gaps of the lever and two piece clamp must be congruently !*

12. Tighten the socket screws (205.2).

13. Adjust the CLOSE limit stop. Set a gap of a half-turn by NR-1S and a third-turn by NR-2S / NR-3S.

14. Perform one full stroke and check the correct setting by the stroke plate.

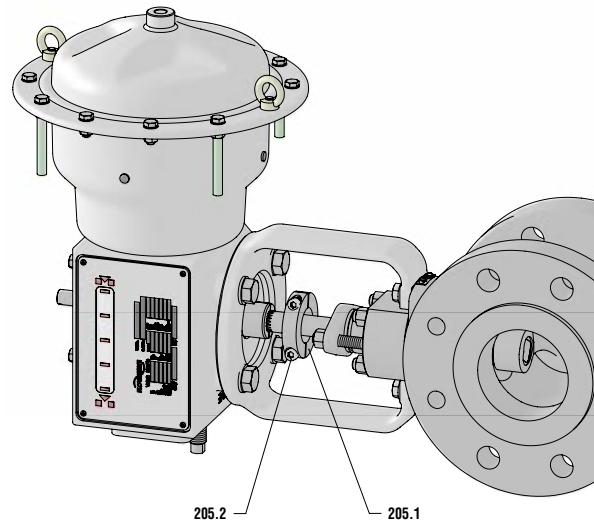

Figure 7: Two piece clamp assembly drawing

Item	Part	Item	Part
205	Two Piece Clamp	205.2	Socket Screw

Table 4: Two piece clamp parts identification

## Seat self-centering procedure

### Set of the floating seat and the plug by the self-centering procedure.

1. Finger tighten the seat retainer if this is not already done, then loosen it by eighth turn.

**NOTICE** *The seat must be sit loosely to float and center itself by the next step!*

2. Move the actuator to the close position and tighten the seat retainer manually to position the seat correctly.

3. Open the valve.

4. Repeat the step 2 - 3 once again.

5. Finally close the valve and tighten the seat retainer to the required torque.

6. Adjust the CLOSE limit stop. Set a gap of a half-turn by NR-1S and a third-turn by NR-2S / NR-3S.

7. Perform three full strokes.

8. The valve is ready for the mounting of the accessories.

9. Refer to the relevant manufacturer's user instruction for information regarding other ancillary equipment.

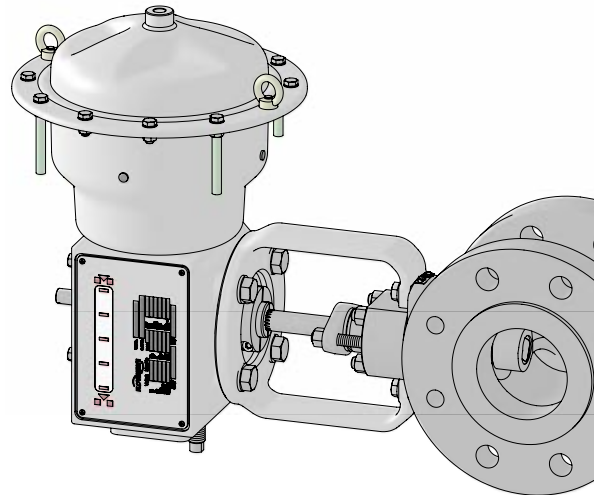

Figure 8: Final assembly drawing



**Reassemble the valve into the pipe**

1. Remove the protective flange covers and coating from the control valve; clean the flange gasket surface.

**NOTICE** *Unsuitable cleaning agents can damage and cause leakage in PTFE and graphite gaskets. Consult a current chemical resistance list before applying.*

2. Install the actuator in an upright position whenever possible. Vertical installation permits easier actuator

maintenance.

3. Install and connect the control valve to the pipeline. Locate gaskets in the center of the body flanges and secure nuts and bolts.

4. For pneumatic actuators, connect the air supply and instrument signal lines.

**NOTICE** *The actuator has rubber plugs (406 + 436). These plugs function as a vent. Remove the lowermost plug to drain out the actuator !*

## 11 Valve Quick-Check

**Apply appropriate personal protective equipment when working on the control valve to prevent hazards arising from the operation. Protect yourself against freezing, burns and cuts by wearing appropriate protective clothing, gloves and eye protection.**

**Do not over-tighten packing.**

**Sudden exposure of the control valve to full working pressure and temperature may cause stress cracks.**

**!** Prior to valve operation, we require, that you check the following conditions to reduce the risk of malfunction and safety related incidents.

No.	Important information	Possible malfunction or safety related incident
1	Avoid critical operating conditions where excessive noise or vibration levels might occur.	<i>Impermissible continuous operation of a control valve under critical conditions can damage the valve.</i>
2	Avoid frequent system start-ups and shutdowns.	<i>Critical operating conditions, which can damage the control valve, may be encountered during system start-up or shut down.</i>
3	Keep the operating medium free of foreign particles.	<i>Installing a suitable strainer upstream of the control valve can prevent foreign particles from damaging the valve.</i>
4	Instrument air must conform to ISA 7.0.01-1996 (with a dew point at least 18°F (10°C) below ambient temperature, particle size below 1 µm and oil content not to exceed 1 ppm)	<i>Contaminated instrument air can damage the accessories and diaphragm rotary actuator or cause them to fail.</i>
5	<b>!</b> Do not touch the body and bonnet ! The temperature of the operating medium is transferred to the surface of the rotary actuator.	<b>Excessive hot surface temperatures can put you at risk for burns. Frigid surface temperatures can put you at risk for freezing.</b>
6	<b>!</b> Critical operating conditions can cause excessive or hazardous levels of vibration or noise.	<b>Impermissible levels of vibration can cause hearing loss, vascular and nerve damage and damage to joints and bones. Use hearing protection when noise levels exceed 80 dB(A).</b>
7	<b>!</b> Incorrect maintenance can result in the emission of hot, cryogenic, and / or toxic operating media.	<b>Incorrect maintenance can put you at risk for heat related burns, freezing, acid burns or poisoning.</b>

Table 5: Basic safety messages for operating the valve

**WARNING** Due to risk of crushing hazard, do not work between the yoke legs while the valve is in operation.

Prior to start-up, we strongly recommend that you:

1. Stroke the valve and compare the plug position indicator on the stem clamp to the stroke indicator plate. The plug should change position in a smooth, linear fashion.

**NOTICE** Graphite packing commonly creates more friction than other materials, such as PTFE. If over tightened, excessive friction may impair smooth control.

2. Adjust instrument signals to ensure a full stroke.

3. Check the packing box bolting to ensure the correct adjustment.

**NOTICE** Over tightening can cause excessive packing wear and high stem friction that may impede plug movement.

4. Continuously increase load until operation parameters are reached.
5. Minor relaxation of the flange bolting is possible after initial assembly. Retorque the bonnet flange bolting if necessary before installation or following an initial temperature excursion to ensure the bonnet gaskets do not leak.

(See User Instructions - MaxFlo 4 Control Valve).

## 12 Actuator Maintenance

Maintenance intervals and service life of an actuator can only be determined empirically on site. The intervals specified in the User Instructions are recommendations and serve only as a guide. Under problematic operating conditions, maintenance intervals may be significantly reduced. We strongly rec-

ommend a site survey followed by establishing a documented procedure for performing the maintenance work. Maintenance personnel should perform and log the work accordingly. The data collected can be used as a basis for dynamically determining the maintenance intervals and activities.

Recommended Maintenance Actions					
No.	Service	Inter- val	Valve Condition		
			Good	Adequate	Inadequate
1	Visual inspection of the actuator	Bi-weekly	No action	Clean actuator stem with a soft cloth	Overhaul or replace actuator after product lifecycle
2	Visual inspection of the tightness	Bi-weekly	No action	Retighten leaky air supply, case bolting	Replace leaky air supply, diaphragm immediately
	Preventive change of the diaphragm	→	Dependent upon results of previous maintenance (see numbers 1 and 2 above) or a minimum of once every 10 years		
3	Visual inspection of case bolting	Yearly	No action	Retighten case bolting if diaphragm leaks externally.	Remove from service and replace case bolting, diaphragm immediately if external leakage persists or if bolting is damaged
4	Operation test	→	No action	Perform 3 full strokes air supply and / or case bolting is modified; check for leakage	

Recommended maintenance actions using the Logix digital positioner with ValveSight diagnostic solution software					
5	Visual inspection of diagnostic interface	Weekly	No action - valve is healthy	Take action per warning	Overhaul or replace required part per alarm
6	Check health parameter of actuator	Warning	No action - actuator is healthy	Check and retighten air supply	Overhaul or replace actuator after alarm
7	Check health parameter of positioner	Warning	No action - positioner is healthy	Start step test	Overhaul or replace positioner after alarm

Table 5: Service activities check list

**!** Prior to valve maintenance, we require, that you check the following conditions to reduce the risk of malfunction and safety related incidents.

No.	Check	Possible malfunction or safety related incident
1	Check for signs of leakage through the case bolting and end flanges.	<i>Tighten the case bolting nuts. See Section 14: Disassembly and Reassembly for instructions. Also see Section 15.</i>
2	Check if all nuts and bolts are securely fastened.	<b>!</b> <b>Avoid critical operating conditions if excess noise or vibration levels occur during operation.</b>
3	Check valve for smooth, full-stroke operation. Unsteady stem movement could indicate an internal valve problem.	<i>Internal valve failure requires an immediate overhaul or rotary actuator replacement by qualified staff.</i>

Table 6: Basic safety messages for maintenance the valve

**!** **WARNING** **Crushing hazard ! Failure to keep hands, hair, and clothing away from all moving parts when operating the control valve can cause serious injury.**

1. Clear all dirt and / or foreign material from the shaft and control valve.
2. If leakage is detected, retighten the bolting.
3. Activities on the valve, see separate document.
4. Make sure all nuts and bolts are securely fastened.
5. If possible, stroke the valve and check for smooth, full-stroke operation. Unsteady stem movement could indicate an internal valve problem.

6. Make sure all accessory brackets and bolting are securely fastened.
7. Check control valve health parameters:
  - Characteristic curves of the valve with flow
  - Upstream pressure
  - Downstream pressure

into the control room.

**NOTICE** *Monitor trim and bonnet components. If nominal and actual values differ by more than 5%, an overhaul may be required.*

## 13 Troubleshooting

**Contact customer service department or contract partner for any fault or defect found, otherwise the manufacturer's guarantee shall be rendered null and void and the manufacturer released from any responsibility. If the user performs the repairs, these User Instructions must be adhered to and carried out in a competent manner. Original Equipment Manufacturer spare parts must be used to make the repair.**

Defect	No.	Possible Causes	Remedy
Shaft does not move	1.1	• No auxiliary energy supply (pneumatic air) to actuator and accessories (positioner, air filter regulator, solenoid valve, limit switch, and/or special accessories)	• Pneumatic actuators: Check supply for leaks Check air pressure (usually 88 psig; 6 bar)
	1.2	• Mounted accessories do not work	• See User Instructions for accessory manufacturer
	1.3	• Pneumatic actuator is defective	• Contact customer service department or contract partner

Defect	No.	Possible Causes	Remedy
Jerky stem movement	2.1	• Damaged shaft	• Contact customer service department or contract partner
	2.2	• Actuator not powerful enough	• Compare actuator specifications on the serial plate with operation specifications of the facility. If incompatible, contact customer service department or contract partner
Shaft travel less than full stroke (0 to 100 %)	3.1	• Air supply pressure too low	• Provide air at the pressure stated on the serial plate (European production only).
	3.2	• Pneumatic actuators: Improper handwheel position	• Move handwheel to limit position , otherwise contact factory for information.
	3.3	• Improperly adjusted or defective positioner	• Readjust positioner to positioner manufacturer's specification
	3.4	• Foreign particles in valve seat or damaged trim	• Contact customer service department or contract partner
No limit switch signal	4.1	• Power supply to limit switch interrupted	• Check power supply (connections, circuit breakers, voltage)
	4.2	• Limit switch out of adjustment	• Readjust limit switch operating distance; see limit switch data sheet
Unstable positioner	5.1	• Defective positioner	• See user instruction of the positioner manufacturer

Table 7: Trouble-shooting

## 14 Disassembly and Reassembly

**The MaxFlo 4 control valve is allowed to be disassembled and reassembled only by qualified staff - personnel who are familiar with disassembling, reassembling, installation and commissioning of this product, and possess the relevant qualifications in their field of activity.**

When performing repairs, personnel are to follow these instructions using only **original** equipment manufacturer (OEM) spare parts and recommended special tools to ensure the reliability of the MaxFlo 4 control valve.

Only Flowserve trained and authorized personnel are allowed to repair (disassemble and reassemble) the MaxFlo 4 in hazard areas.

Valves for oil and grease-less service or oxygen service only be disassembled and reassembled in clean rooms (ISO 14644- ISO 8, US FED STD 209 E - M 6.5, or equivalent).

**⚠ WARNING** Control valves are pressure vessels. Improper opening of the valve or actuator can result in bodily injury.

**⚠** Prior to disassemble and reassemble, we require, that you check the following conditions to reduce the risk of malfunction and safety related incidents.

No.	Important information	Possible malfunction or safety related incident
1	Disregarding these instructions may bring serious or harmful consequences.	<i>Failure to comply with these user instructions will render the manufacturer's guarantee and liability null and void. Unless otherwise agreed, the manufacturer's general terms and conditions of sale shall apply.</i>

2	<b>!</b> Always observe system safety instructions when preparing for and performing the repair procedure.	Potential hazards and their sources are under the operator's influence. The operator must observe national and international environmental regulations for control valve removal from the pipe and cleaning. Permissible exposure limits must be maintained, appropriate personal protective equipment must be used and service personnel must be properly instructed in performing the repair procedure.
3	<b>!</b> Make sure the pipeline is depressurized and in ambient state, also a suitable rigging (e.g. Endless Sling) and securing devices (e.g. Vee Trough with Stands / Vise) are readily available.	Remove the MaxFlo 4 from the pipeline in a depressurized and ambient state. Failure to do so can cause serious personal injury. The control valve is not equipped with integral stands, therefore guard against the valve from tipping over. Bodily injuries can be the result. Use appropriate clamps, blocking or other stabilizing support. Attachment to overhead crane can ensure stability.
4	Confirm that you have the required spare parts at the site.	Not having the full complement of parts, accessories and tools can slow or stop repair work.
5	<b>!</b> Confirm that you have the required tools available to manage the disassembly and reassembly (See Section 16: Special Tools).	Improper tools and / or improper use of tools can result in personal injury or damage to the parts.
6	Review the serial plate information to identify the actuator. The serial number and the part numbers needed are required when ordering spare parts.	A serial plate used for product identification is attached on every control valve (See Section 3: Product Identification).
7	Check all parts for damage such as scoring, deformities, corrosion or overexpansion.	If in doubt, replace faulty parts. Never reuse gaskets.

Table 8: Basic safety messages for repairing the control valve

After these requirements are confirmed the control valve can be maintained and repaired.

## Description of the Procedure

**!** **WARNING** Actuators are pressure vessels. Improper opening of the actuator can result in bodily injury. The steps described should only be performed when a transfer case is mounted.

1. Attach a marking to hold the position of lever and shaft for reassembling.
2. Control the air supply so the actuator move to the center position.
3. Turn the socket screws of the two piece clamp counter clockwise to loosen (See Figure 9: Remove the actuator).
4. Turn the hex bolts counter clockwise to loosen.
5. Lift off the actuator and the two piece clamp.
6. Disconnect the air supply and place the actuator assembly on a table for disassembly.

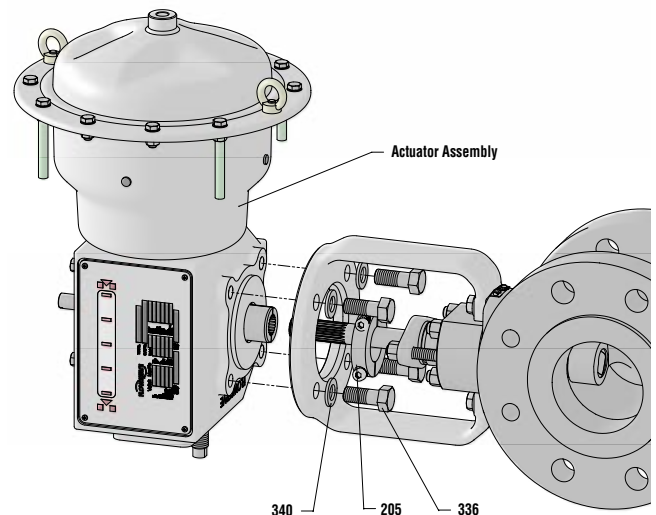

Figure 9: Remove the actuator

Item	Part	Item	Part
336	Hex Bolt	205	Two Piece Clamp
340	Flat Washer		

Table 9: Coupling parts identification

## Disassembly instructions of the actuator assembly.

1. Pull off the pipes (333).  
(See Figure 10: Disassemble / Reassemble the actuator).
2. Hold against turning the ring nut (209) and turn the hex nuts (335) clockwise to loosen.
3. Hold against turning the flange hex nut (351) and turn the hex screws (335) clockwise to loosen.
4. Hold against turning the flange hex nut (351) and turn the hex screws (334) clockwise to loosen.
5. Remove the upper diaphragm case (215).
6. Pull out the diaphragm (225).
7. Check stressed surface areas for damage such as scoring and deformities.

## Reassembly instructions of the actuator assembly.

8. Lubricate all bolt and screw threads with a suitable, approved lubricant (See Section 16: Lubricants).
9. Overdraw the new diaphragm (225) on the diaphragm plate.
10. Put on the upper diaphragm case (225) the diaphragm bead must lie flush in the centering groove.
11. Install and finger tighten the four hex screws (334), flat washers (214) and flange hex nuts (351) first.
12. Install and finger tighten the hex screws (335), flat washers (214) and flange hex nuts (351).
13. Install and finger tighten the ring nuts (209), flat washers (214) and hex screws (335).
14. Tighten the nuts (351) in four steps - 30%, 60%, 100%, and all around 100% - using a crosswise pattern.  
(See Section 15: Torque Requirements)
15. Install the plastic pipe (333).
16. Perform 3 full strokes and check the actuator for smooth and full-stroke operation.
17. Log the maintenance interval and the work performed.

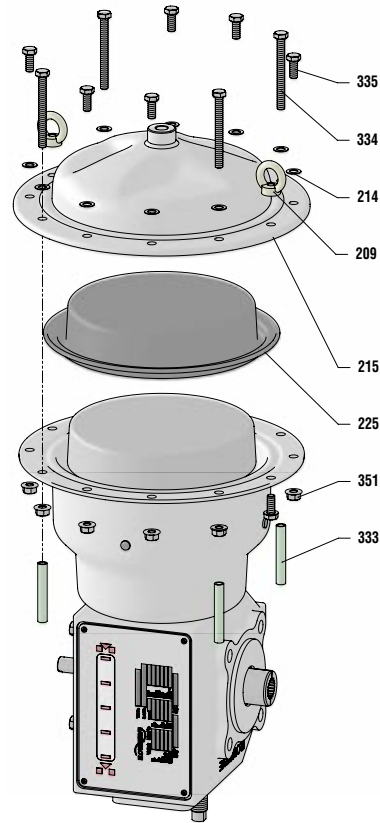

Figure 10: Disassemble / Reassemble the actuator

Item	Part	Item	Part
209	Ring Nut	333	Pipe
214	Flat Washer	334	Hex Screw
215	Upper Diaphragm Case	335	Hex Screw
225	Diaphragm	351	Flange Hex Nut

Table 10: Actuator parts



### Reassemble the actuator:

1. Rotate the shaft / plug out of the seat by about 30 degrees (center position).
2. Connect the air supply and control the air so that the actuator move to the center position ( see stroke plate ).
3. Mount the two piece clamp and the actuator so that the marking match between the shaft and lever.
4. Mount the flat washer (340) and tighten the hex bolts (336) clockwise.
5. Turn the socket screws of the two piece clamp (205) clockwise to tighten.  
(See Figure 11: Assemble the actuator)
6. Set the floating seat.  
(See Page 8: Seat self-centering procedure)

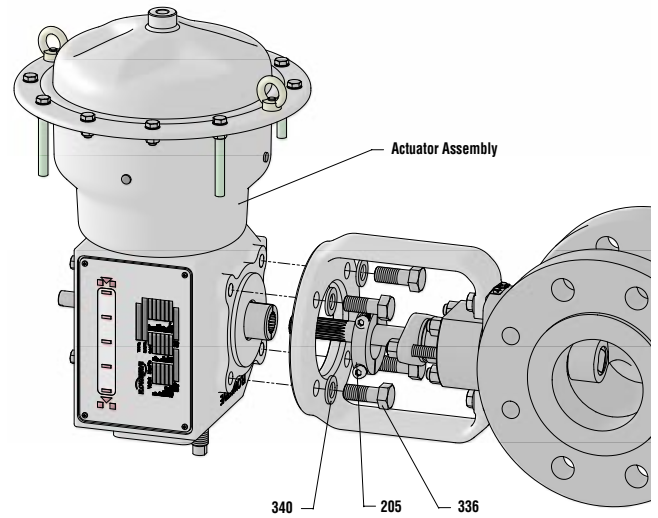

Figure 11: Remove the actuator

Item	Part
336	Hex Bolt
340	Flat Washer

Item	Part
205	Two Piece Clamp

Table 11: Coupling parts identification

## 15 Torque Requirements

Torque Requirements for CASING BOLTING (334 + 351, 335 + 351 and 209) per actuator size			
Unit	NR-1S	NR-2S	NR-3S
Nm	5		
ft lb	3.69		

Torque Requirements for COVER PLATE BOLTING (337) per actuator size			
Unit	NR-1S	NR-2S	NR-3S
Nm	9	25	25
ft lb	6.64	18.44	18.44

Torque Requirements for TRANSFER CASE BOLTING (256) per actuator size			
Unit	NR-1S	NR-2S	NR-3S
Nm	9	25	63
ft lb	6.64	18.44	46.47

Torque Requirements for VALVE / YOKE HEAD HEX BOLTS (107) per actuator size			
Unit	NR-1S	NR-2S	NR-3S
Nm	63	63	156
ft lb	46.47	46.47	115.06

Torque Requirements for ACTUATOR / YOKE HEAD HEX BOLTS (336) per actuator size			
Unit	NR-1S	NR-2S	NR-3S
Nm	35	156	305
ft lb	25.81	115.06	224.96

## 16 Lubricants

Use		Lubricant / Antiseize	
		WW (World Wide)	EU (European Union)
Standard, from -40°F to +158°F -40°C to +70°C	Actuator O-Ring's (237, 247)	DOW Molykote 55 O-Ring	Klüber Unisilikon L 250 L
	Threads of the Actuator (107, 211, 250, 330, 334, 335, 336, 365) and Guide (247, 358)	Fastorq A/G	Klüberpaste 46 MR 401
Low temperature, from -76°F to -40°F -60°C to -41°C	Actuator O-Ring's (237, 247) and Guide (247, 358)	Alcohol 96%	
	Threads of the Actuator (107, 211, 250, 330, 334, 335, 336, 365)	Fastorq A/G	Klüberpaste 46 MR 401

## 17 Disposal

Up to 95 % of the MaxFlo 4 NR rotary actuator is metal. The remaining materials are synthetic, rubber, polytetrafluoroethylene (PTFE), polycarbonate (PC), acryle, paint and lubricants.

**NOTICE** *Potential hazards and their sources are under the operator's influence. The operator must observe national and international environmental conditions for rotary actuator removal from the pipeline and cleaning. Permissible limit values must be maintained to ensure suitable protective measures; service personnel must be properly instructed in performing the disassembly and reassembly procedure.*

The valve should be professionally disassembled and reassembled. Metal parts should be scrapped, with the remaining materials disposed of according the national conditions.

Peripheral units (accessories) should be recycled according the relevant manufacturer's User Instructions.

# 18 Parts List

M = Diaphragm Kit  
E = Gasket Kit

Item #	Part	Mat.	Spare Parts
107	Hex Head Bolt	SS	
112	Flat Washer	SS	
201	Yoke, painted	CS	
203	Lower Diaphragm Case, painted	CS	
205	Two Piece Clamp	CS	
206	Stud Bolt	SS	
209	Ring Nut	SS	
211	Actuator Stem	SS	
213	Stroke Plate	SS/Acryl	
214	Phillips Panhead Screw	SS	
215	Upper Diaphragm Case, painted	CS	
216	Stroke Indicator	SS	
218	Rear Cover Plate	SS	
225	Diaphragm	Rubber	M
227	Diaphragm Plate	Alu	
229	Compression Spring	FDSiCr	
235	NAMUR Shaft	SS	
237	O-Ring	Rubber	E
245	Socket Head Bolt	SS	
247	Bearing	SS/PTFE	E
249	Lever	CS	
250	Pin	SS	
251	Roller	SS	
256	Hex Nut	SS	
258	Bearing	SS/PTFE	
261	Flat Washer	SS	
281	Serial / Stroke Plate	SS/Acryl	
330	Limit Stop	SS	
331	Serrated Washer	SS	
333	Pipe	Rubber	
334	Hex Screw	SS	
335	Hex Screw	SS	
336	Hex Head Bolt	SS	
337	Hex Head Bolt	SS	
340	Flat Washer	SS	
341	Flat Washer	SS	
347	Lock Nut	SS	
351	Flange Hex Nut	SS	
358	Bushing	SS/PTFE	
359	Retaining Ring	SS	
361	Beg Pin	SS	
363	Cover Plate, painted	CS	
364	Clevis	SS	
365	Hex Nut	SS	
406	Blanking Plug	Rubber	

407	Rectangular Plug	Rubber	
436	Rubber Plug	Rubber	

Optional manual handwheel

397.1	Handwheel	CS	
397.2	Indicator Plate	SS	
397.3	Hex Nut	CS	
397.4	Lock Nut	CS	
397.5	Socket Head Capscrew	CS	
397.6	Stem	SS	
397.7	Stop Nut	CS	

Table 12: Actuator parts

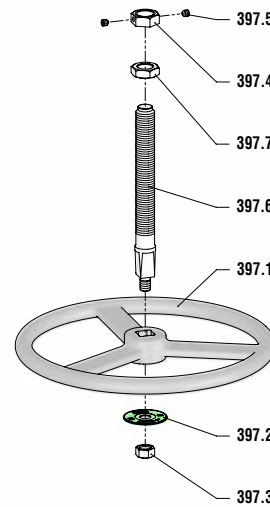

S

Figure 13: Optional handwheel parts

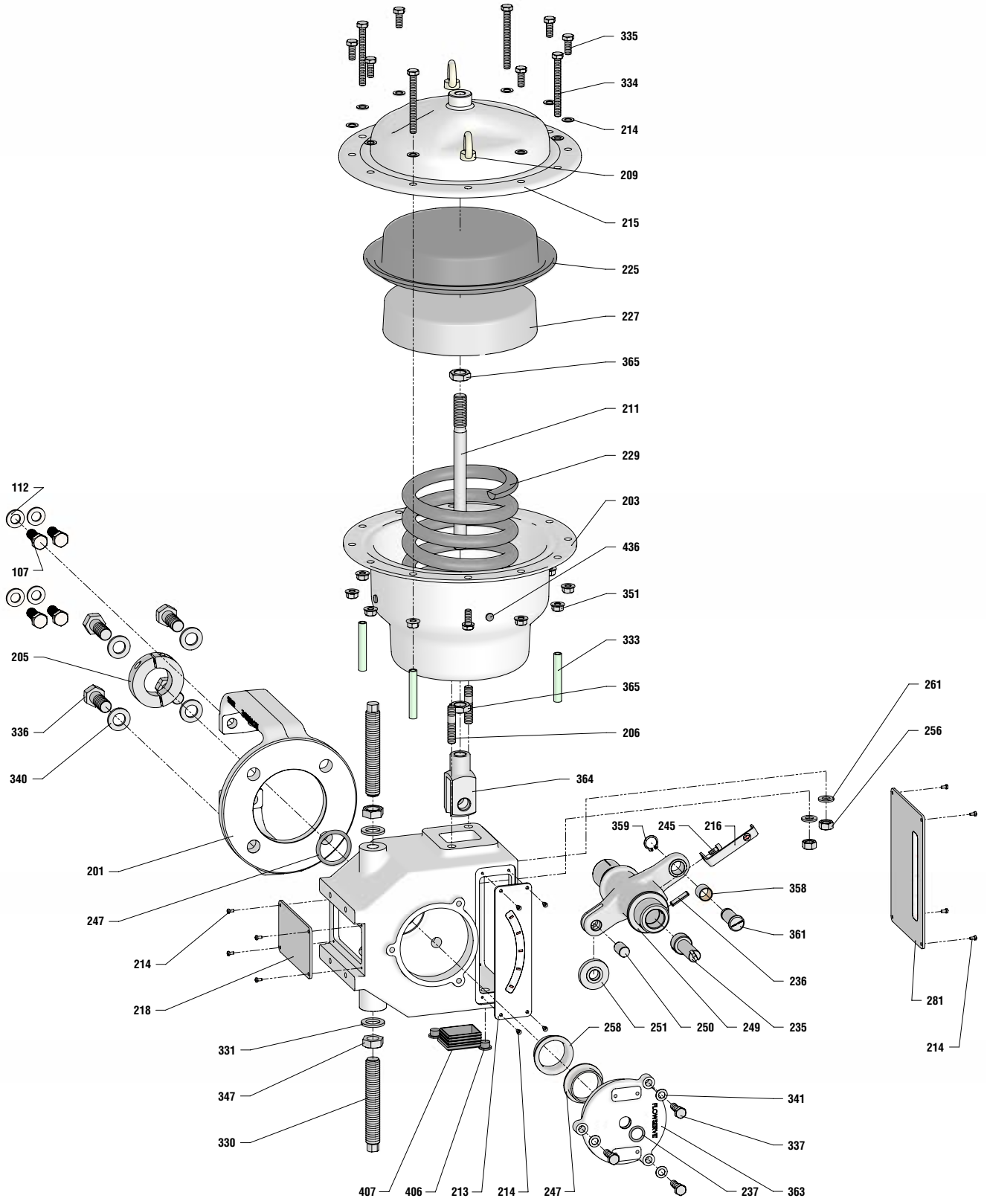

Figure 12: Complete actuator parts



FCD VLENIM0065-01 A4 03/17 Printed in Europe

**To find your local Flowserve representative**  
or for more information about Flowserve Corporation, visit  
[www.flowserve.com](http://www.flowserve.com).

Flowserve Corporation has established industry leadership in the design and manufacture of its products. When properly selected, this Flowserve product is designed to perform its intended function safely during its useful life. However, the purchaser or user of Flowserve products should be aware that Flowserve products might be used in numerous applications under a wide variety of industrial service conditions. Although Flowserve can (and often does) provide general guidelines, it cannot provide specific data and warnings for all possible applications. The purchaser/user must therefore assume the ultimate responsibility for the proper sizing and selection, installation, operation, and maintenance of Flowserve products. The purchaser/user should read and understand the Installation Operation Maintenance (IOM) instructions included with the product, and train its employees and contractors in the safe use of Flowserve products in connection with the specific application.

While the information and specifications contained in this literature are believed to be accurate, they are supplied for informative purposes only and should not be considered certified or as a guarantee of satisfactory results by reliance thereon. Nothing contained herein is to be construed as a warranty or guarantee, express or implied, regarding any matter with respect to this product. Because Flowserve is continually improving and upgrading its product design, the specifications, dimensions and information contained herein are subject to change without notice. Should any question arise concerning these provisions, the purchaser/user should contact Flowserve Corporation at any one of its worldwide operations or offices.

© 2004 Flowserve Corporation, Irving, Texas, USA. Flowserve is a registered trademark of Flowserve Corporation.

#### **USA**

Flowserve Flow Control Division  
1350 N. Mt. Springs Parkway  
Springville, UT 84663

USA

Phone: +1 801 489 8611

Fax: +1 801 489 3719

#### **Austria**

Flowserve Control Valves GmbH  
Kasernengasse 6  
9500 Villach

AUSTRIA

Phone: +43 (0) 4242 41181 - 0

Fax: +43 (0) 4242 41181 - 50

#### **India**

Flowserve India Controls Pvt Ltd.  
Plot # 4, 1A, Road #8 EPIP White-  
field Bangalore, Karnataka, 560066

INDIA

Phone: 91 80 40146200

Fax: 91 80 28410286

#### **China**

Flowserve Fluid Motion and  
Control (Suzhou) Co., Ltd.

No. 35, Baiyu Road,  
Suzhou Industrial Park,  
Suzhou Jiangsu Province,  
P.R. 215021 CHINA

Phone: 86 512 6288 8790

Fax: 86 512 6288 8736

#### **Singapore**

Flowserve Pte. Ltd.

12 Tuas Avenue 20

Republic of Singapore 638824

SINGAPORE

Phone: +65 6879 8900

Fax: +65 6862 4940

#### **Saudi Arabia**

Flowserve Abahsain Flow Control Co.,  
Ltd.

Makkah Road, Phase 4

Plot 10 & 12, 2nd Industrial City

Damman, Kingdom of Saudi Arabia

Phone: +966 3 857 3150 X 243

Fax: +966 3 857 4243