

COMBIMASS[®]

Technical data
COMBIMASS[®]eco

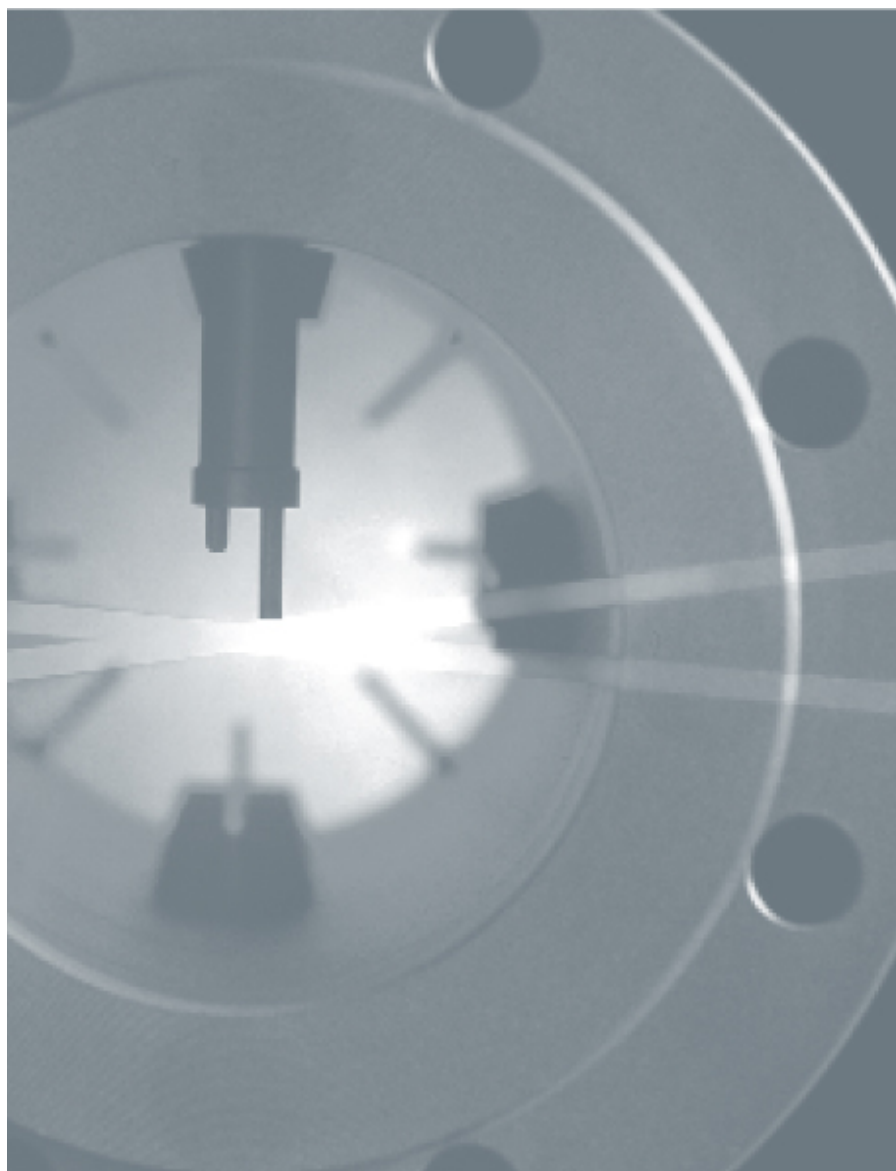

THE SYSTEM

The field transmitters of the COMBIMASS[®]eco series are suitable for gas flow measurement and cover a wide range of different applications. The instruments can be employed for process temperatures up to 220°C and are available in explosion proof versions. The flow transmitters apply thermal dispersion technology in order to measure directly the normal volumetric or gas mass flow, regardless of the operating pressure and temperature of the medium.

All units of the COMBIMASS[®] series are characterized by high-performance digital signal processing. Important features of the transmitter electronics for the purposes of practical operation are the temperature compensation and the opportunity to select different measuring modes (choice between constant current or constant temperature principle).

The electronics of the COMBIMASS[®]compact is located in a compression-proof dual compartment stainless steel enclosure. Optionally a 10 digits LED display with control panel is available for indication of actual flow rate or totalized flow as well as for field programming of the flow meter.

For transmission of the flow signal an isolated 4-20 mA analog output as well as a field selectable pulse output are available. For intrinsically safe operation a dedicated process interface module has been developed for the power supply of the flow transmitter. In such a case, the signal output is done via an I/O module installed downstream of the process interface module. The circuitry of the process interface module and the I/O module is located in a top hat rail housing for easy switch cabinet assembly. Also an optionally available graphic display can be installed there.

The flow transmitter can be combined with a wide range of different sensors of the COMBIMASS[®] family and assembled individually according to the specific application. Each flow meter will be tested prior to shipment and calibrated at our CAMASS[®] calibration centre under actual operating conditions.

SMART FEATURES

- Thermal flow meter for direct measurement of normal volumetric or gas mass flows
- Flow rate measurement unaffected by pressure and temperature fluctuations
- Pressure-proof dual compartment stainless steel enclosure
- Compact and rugged design for exceptional reliability
- Easy to install and service
- Unmatched accuracy due to digital signal processing
- Temperature compensated flow rate measurement
- Choice of different measuring modes
- Expandable due to modular design
- Wide range of different sensors for each specific application
- EEx [ed] Zone 1 / EEx [ia] Zone 0 optionally available

APPLICATIONS VERSATILITY

- Compressed air – flow rate measurement and balancing
- Air and technical gases
- Combustion gases such as methane, propane, natural gas, etc.
- Exhaust air and waste gases
- Combustion air in incineration plants
- Biogas in wastewater and environmental installations
- Prozessgase
- Process gases
- Gases and gas mixtures of known composition

SPECIFICATIONS

SPECIFICATIONS

| | |
|----------------------|---|
| Measuring principle | Gas flow measurement based on thermal dispersion technology |
| Applications | Compressed air, air, technical gases, inert gases, supply gases, combustion gases, process gases, explosive gases, gases and gas mixtures of known composition, depending on choice of sensor |
| Measured parameter | <ul style="list-style-type: none"> ■ Gas mass flow [kg/h] ■ Normal volumetric flow [Nm³/h] ■ Normal flow velocity [Nm/s] |
| Signal processing | Microprocessor based, fully digital signal processing |
| Measuring modes | <p>Constant current or constant temperature principle</p> <p><u>Note:</u> The measuring mode will be selected by our qualified technicians depending on the application requirements during calibration of the flow meter and may not be changed by the operator.</p> |
| Calibration | One calibration group with advanced temperature compensation |
| Enclosure | Pressure proof dual compartment enclosure, 1.4571, Ø 50 mm |
| Protection class | IP 65 / IP 68 |
| Explosion protection | <p>Approvals according to ATEX (optional):</p> <ul style="list-style-type: none"> ■ EEx [ed] – Zone 1 ■ EEx [ia] – Zone 0 |
| Ambient conditions | Ambient temperature -40°C to 80°C, Relative humidity 80% |

TECHNISCHE DATEN

| | |
|---|--|
| Power supply | 18 – 36 VDC Power supply via standard supply units possible For intrinsically safe operation – EEx [ia] – power supply via process interface module |
| Power consumption | max. 1,1 Watt |
| Reproducibility (electronics) | 0,125% of reading |
| System accuracy (electronics) | 0,25% of reading + 0,025% of full scale |
| Measuring accuracy (depending on application and type of calibration) | 2,5% of reading + 0,1% of full scale (standard applications) 2,5% of reading + 0,2% of full scale (extreme applications) 1% of reading + 0,1% of full scale (optional – please, call factory) |
| Flow range (1013 mbar, 0°C) | 0,08 – 46 Nm/s (standard) 0,08 – 240 Nm/s (optional) |
| Turndown ratio | 10 : 1 to 100 : 1 |
| Field display / control (optional) | <ul style="list-style-type: none"> ▪ 10 digits, alphanumeric LED display for field indication of flow rate or totalized flow ▪ Integrated totalizer ▪ Control pad for field programming of the flow meter using a magnetic pin ▪ Easy-to-use menu for transmitter set-up |
| Graphic display (optional) | <ul style="list-style-type: none"> ▪ Remote graphic display (wall or switch cabinet mounting) ▪ Simultaneous indication of flow rate and totalized flow ▪ Integrated totalizer ▪ Touch pad for easy programming of the flow meter ▪ Easy-to-use menu for transmitter set-up |
| Signal output (isolated) | <p>1 x analog output: 4-20 mA, active load < 400 Ohm 10 Bit resolution</p> <p>1 x impulse output: field selectable max. 30 impulse/s</p> |

SPECIFICATIONS

| | |
|-------------------|--|
| Choice of sensors | Transmitter can be combined with different sensors of the COMBIMASS [®] series: |
| | Sensor geometry: 1-pin type, 1½-pin type, 2-pin type |
| | Process temperature: max. 220°C |
| | Operating pressure: max. 100 bar |
| | Diameter of sensor rod: 12 mm, 18 mm |
| | Materials: 1.4571 (standard) 1.4435 (optional) |
| | Approvals: PED test certificate, modules B+F or module G (optional) |
| | Certificates: 3.1B material certificate (optional) |
| | Type of flow element: Insertion flow element Inline flow element |
| | Process connections: Compression fitting, butt weld, screw, flange (DIN, ANSI) |
| | Hot tapping: manually actuated with ball valve |

INLET AND OUTLET STRAIGHT PIPE RUNS

INLET AND OUTLET STRAIGHT PIPE RUNS

General information To achieve high accuracy in flow rate measurement as specified, consideration of sufficient inlet and outlet straight pipe runs according to DIN ISO 5167-1 is crucial during installation of the flow transmitter. Reasonable measuring results can also be achieved with shortened inlet and outlet straight pipe runs according to the below specifications.

If sufficient inlet and outlet straight pipe runs are not available, please call factory. It might be possible to achieve the required measurement accuracy, if a special calibration can be carried out at our CAMASS[®] calibration centre by simulating the actual operating conditions, the range of flow rates and the piping.

Alternatively, the installation of a flow conditioner may allow to achieve accurate measuring results when space is restricted.

Reduction piece

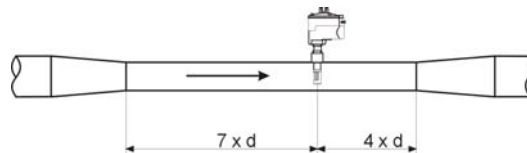

Extension piece

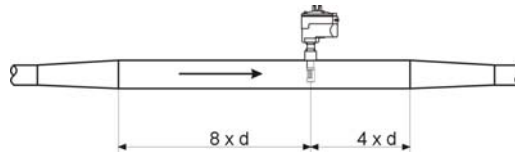

One 90° elbow

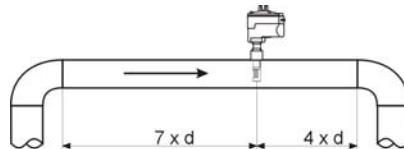

Two 90° elbows in one plane

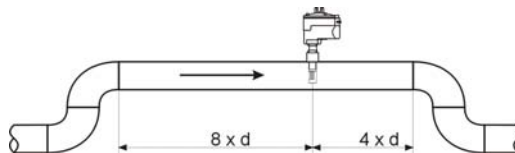

Two 90° elbows in two planes

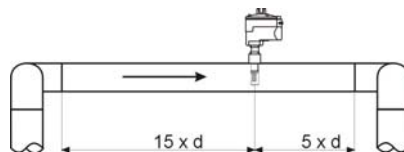

Three 90° elbows in three planes

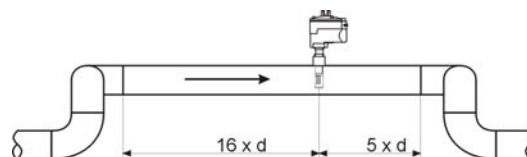

DIMENSIONS

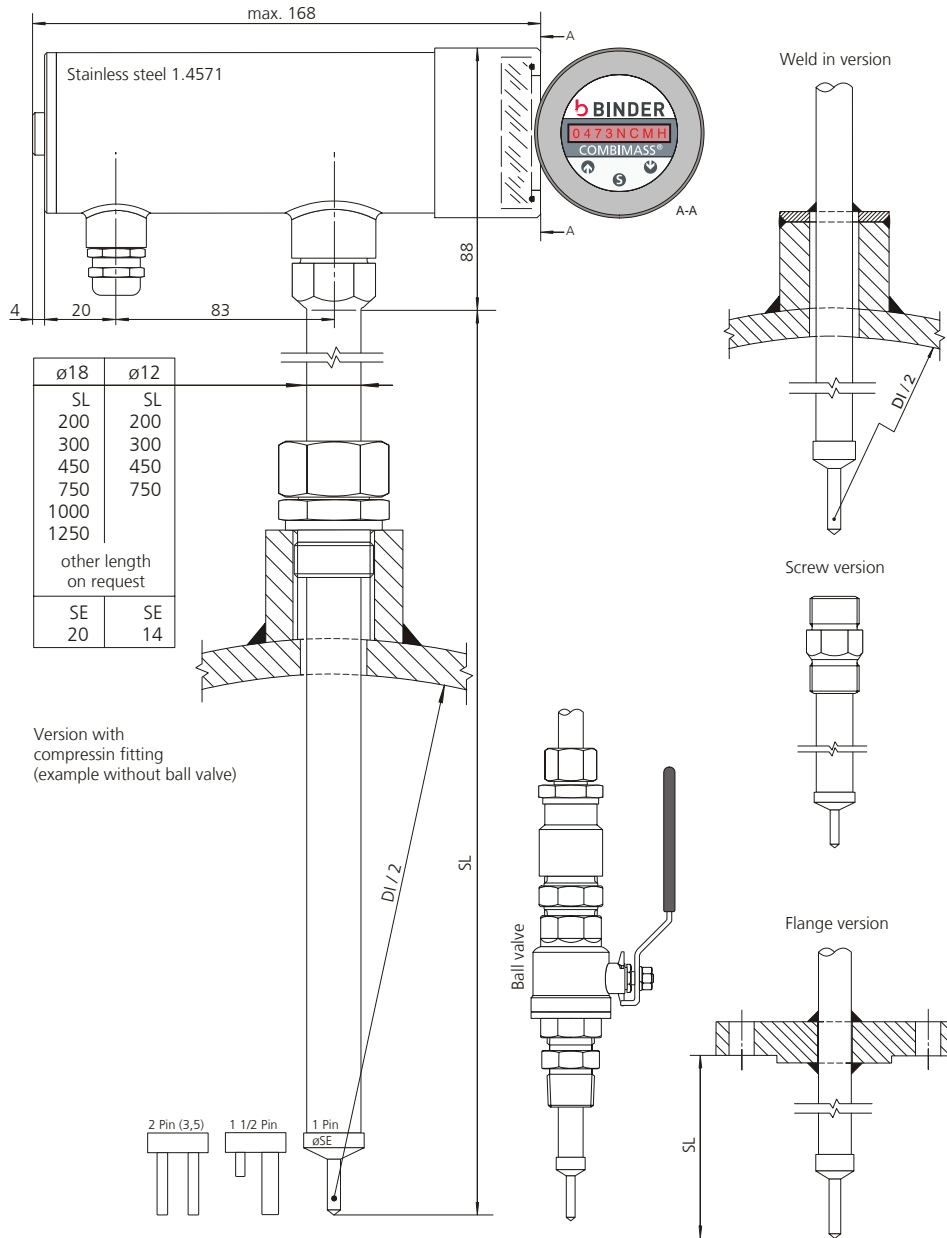

IMPRESSUM

BINDER GmbH
Buchbrunnenweg 18
89081 Ulm, Germany
Tel. +49 731 18998-0
Fax +49 731 18998-88

info@binder-flow.com
www.binder-flow.com

Technical data
TD_COMBIMASS eco_E_2004-04