



*P3/EP3
Modular Linear Positioner*

*Installation
Operation
Maintenance*



Contents

1. Introduction	3
Safety instruction	3
2. Storage	4
General	4
Storage indoors	4
Storage outdoors or for a longer period	4
Storage in a warm place	4
3. Design	5
4. Variants	6
Standard designs	6
Optional equipment	6
5. Function	7
General	7
Increase in signal pressure	7
Decrease in signal pressure	7
6. Installation	8
Air supply requirements	8
Mounting	9
Connections	11
Direct / Reverse function	11
Single acting positioner	12
Electrical connections	13
Control drawing	14
7. Adjustments	15
Gain	15
Default settings	15
Setting the zero position and span	15
8. Maintenance/service	16
Valve block	16
Flapper nozzle	17
Gain screw	17
Integral I/P converter	17
Feedback arm / Spindle	18
9. Trouble shooting	19
10. Technical data	20
11. Spare Parts List	22

1. Introduction

The PMV P3 is a modular Positioner system designed for use on control valves with linear motion. The basic unit is the P3 positioner, which is available for single acting. The I/P converter can be integral, located in a separate mounted module (Ex), or located elsewhere. The P3 can be equipped with connection blocks for pressure gauges to indicate:

- actuator pressure
- air supply pressure
- input signal pressure



Safety instruction

Read the safety instructions in this manual carefully before using the product. The installation, operation, and maintenance of the product must be done by staff with the necessary training and experience.



PMV P3 basic unit



PMV P3 with explosion proof I/P

2. Storage

General

The PMV positioner is a precision instrument. Therefore it is essential that it is handled and stored in the correct way. Always follow the instructions below!

N.B. As soon as the positioner is connected and started, an internal air bleed will provide protection against corrosion and prevent the ingress of moisture. For this reason, the air supply should always be kept on.

Storage indoors

Store the positioner in its original packaging. The storage environment must be clean, dry and cool, (15 to 26°C, 59 to 79°F).

Storage outdoors or for a longer period

If the positioner must be stored

outdoors, it is important that all the cover screws are tightened and that all connections are properly sealed. The unit should be packed with a desiccant in a plastic bag or similar, covered with plastic, and not exposed to sunlight, rain, or snow.

This is also applicable for long-term storage (more than 1 month) and for long transport by sea.

Storage in a warm place

When a positioner is stored in a warm place with a high relative humidity and is subjected to daily temperature variations, the air inside the unit will expand and contract.

This means that air from outside the unit may be drawn into the positioner. Depending on the temperature variations, relative humidity, and other factors, condensation and corrosion can occur inside the unit, which in turn can give rise to functional disorders or a failure.

3. Design

The P3 positioner comprises a basic module with a single acting valve block. It also includes a sealed chamber with terminals for the electrical input signals.

The I/P unit can be built into the main housing (as shown in the figure below) or

located externally (explosion proof), see section "Variants".

The adjusting screws and knobs are accessible under the removable sealed aluminium cover.

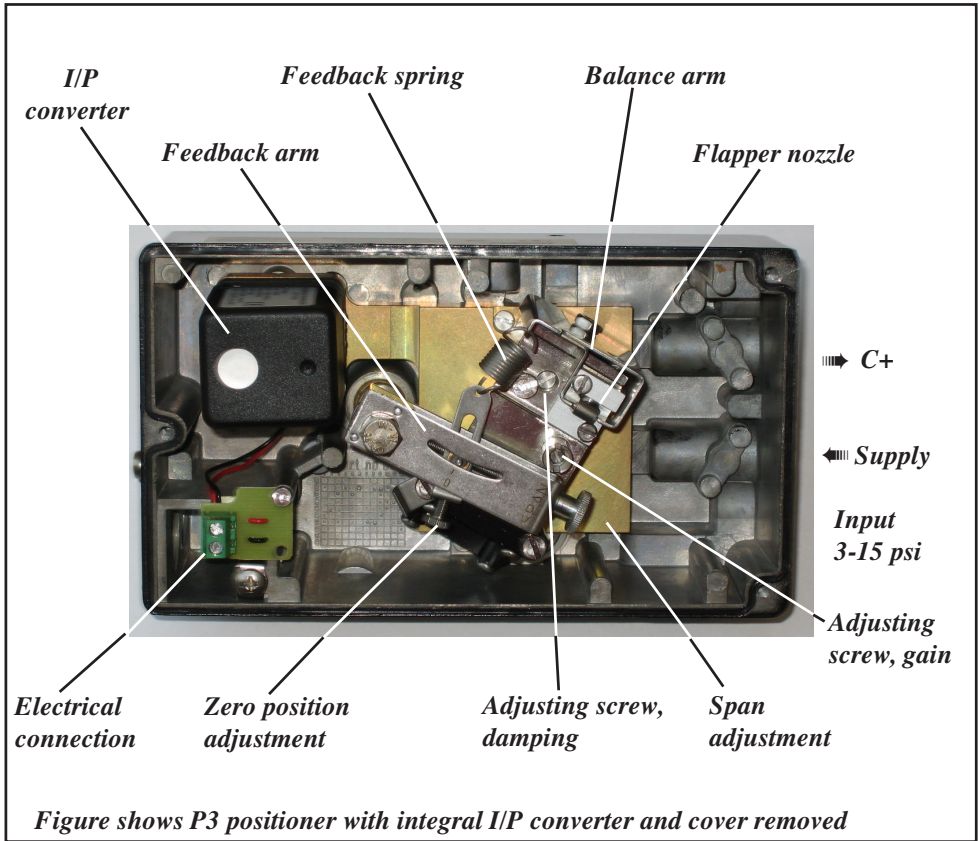

4. Variants

Standard designs

P3/EP3 is available single acting.

I/P converter can be integral or located elsewhere.

P3

Pneumatic, single acting, to be connected to an external I/P converter.



P3/EP3

EP3, EP3IS

Electro-pneumatic, single , with integral I/P converter. Intrinsically safe model also available.

EP3EX

Explosion proof model, I/P converter located in separate, sealed enclosure.



EP3 EX

Optional equipment

P3 / EP3 positioner can be equipped with connection blocks and pressure gauges for:

- input signal pressure
- input air supply pressure
- output pressure

5. Function

General

The P3 positioner operates on the force balance principle. Changes are initiated by the signal pressure from the I/P converter. The functionality is described briefly below.

Single action

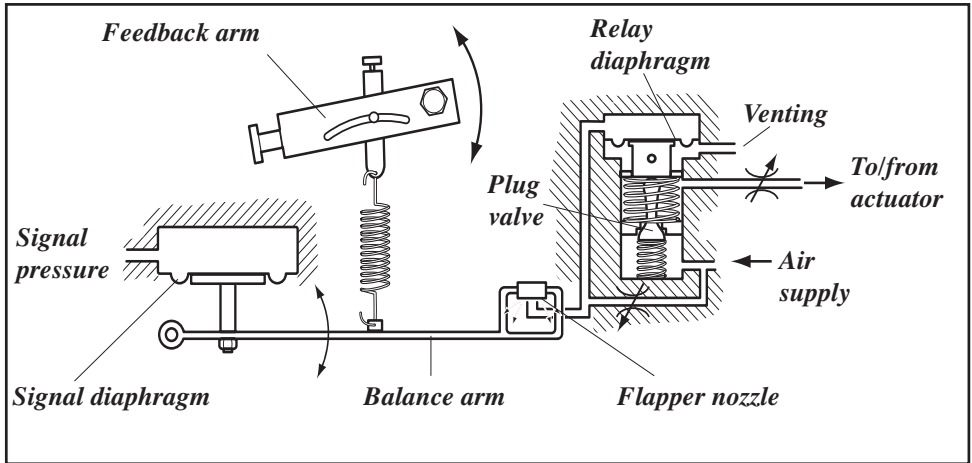

Increase in signal pressure

When the air pressure on the signal diaphragm increases, the balance arm is pressed down and the flapper nozzle closes. The pressure on the relay diaphragm then increases and the plug valve opens.

Air is now supplied to the actuator, the spindle movement rotates the feedback arm, the balance arm is lifted, and the flapper nozzle opens. The pressure on the relay diaphragm is reduced and the plug valve reduces the air flow to the actuator. An equilibrium position is thus reached and the valve being controlled is in the desired position.

Decrease in signal pressure

When the air pressure on the signal diaphragm is reduced, the balance arm is lifted and the flapper nozzle opens. The pressure on the relay diaphragm is then reduced and the plug valve upper seal opens and vents.

Air is now ventilated from the actuator and its spindle moves. The actuator movement goes back through the arm mechanism (see figure) to the positioner spindle, which rotates the feedback arm. The balance arm is now lowered by the reduced spring force and closes the flapper valve. An equilibrium position is thus reached and the valve being controlled is in the desired position.

6. Installation

Air supply requirements

Max. air supply pressure, see the section Technical Data on page 20.

The supply air must be free from moisture, water, oil, and particles.

The supply air must be dried or be treated in such a way that its dew point is at least 10°C (18°F) below the lowest expected ambient temperature.

Before the air supply is connected to the positioner, we recommend the hose is opened freely for 2 to 3 minutes to allow any contamination to be blown out. Direct the air jet into a large paper bag to trap any water, oil, or other foreign materials. If this indicates

that the air system is contaminated, it should be properly cleaned.

To ensure a stable and problem-free operation, we recommend the installation of a filter/pressure regulator <40µ as close to the positioner as possible.



WARNING. Do not direct the open air jet towards people or objects because it may cause personal injury or damage.

Poor air quality is the main source of problems in pneumatic systems.

Mounting according to IEC 534-6

N.B. If the positioner is installed in a hazardous environment, it must be of a type approved for this purpose.

The positioner has an ISO F05 footprint (A). The holes are used to attach it to the mounting bracket (B), which is suitable for most types of linear actuators.

The arm (C) is graduated in mm and

inches. The scale is used to adjust the pin (D) so its position corresponds to the stroke of the valve stem.

It is important that the positioner's spindle and the arms, that transfer the actuator movements, are correctly mounted. Any tension between these parts can cause incorrect operation and abnormal wear.

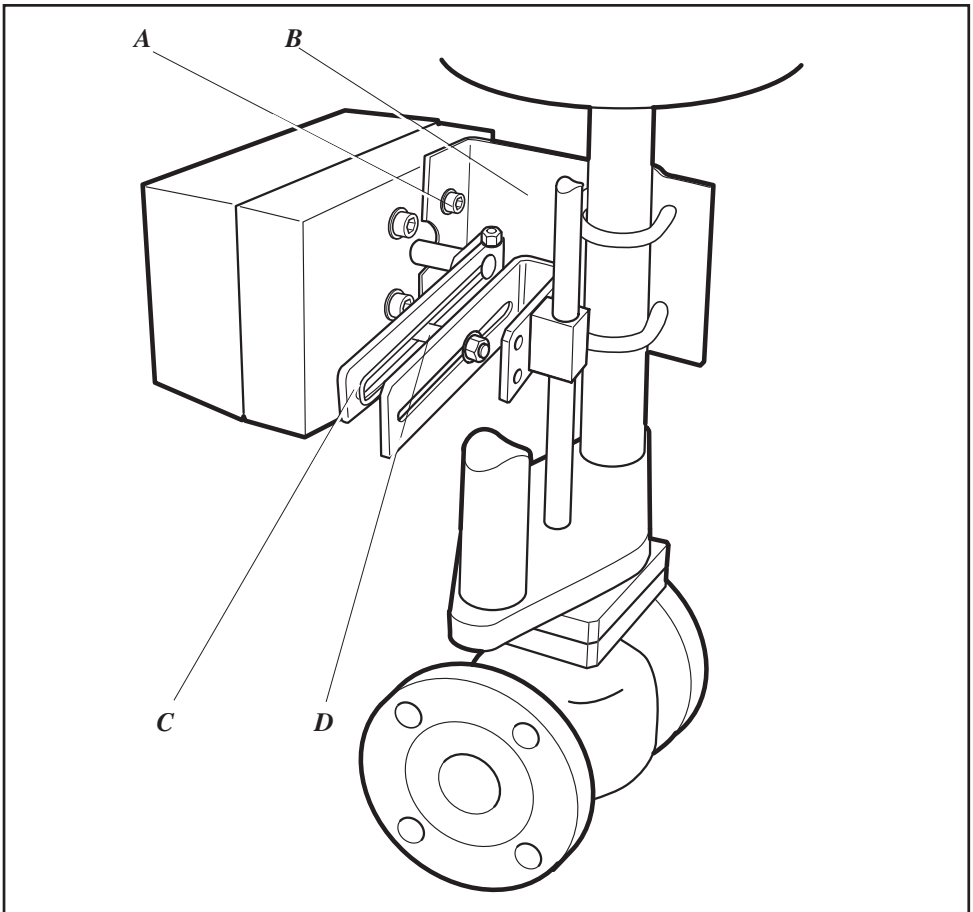

Mounting instructions for P3/EP3 with mounting kit 30168S

P2-H1_rev.0_091113_mr

Non related drawing
Indicazioni per il montaggio
 dell'azionatore

Mounting Instructions for P3/EP3 Positioner with Mounting Kit 30168S.

Combination	Bracket position	Shaft position	Flapper position
Air to open – reverse	Left hand side	Left hand side	B
Air to close – direct	Left hand side	Left hand side	A
Air to open – direct	Right hand side	Right hand side	A
Air to close – reverse	Right hand side	Right hand side	B

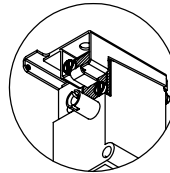

Flapper nozzle position: A

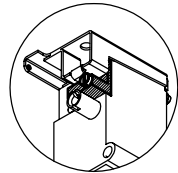

Flapper nozzle position: B

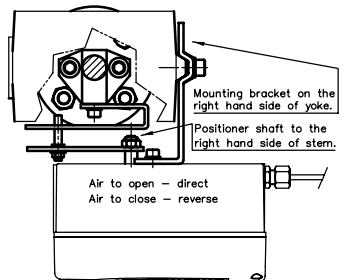
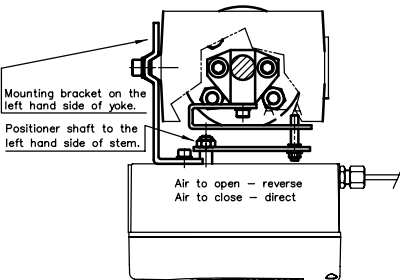
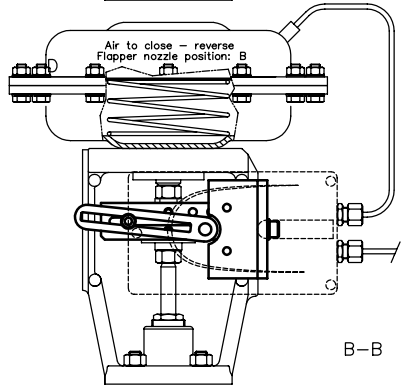
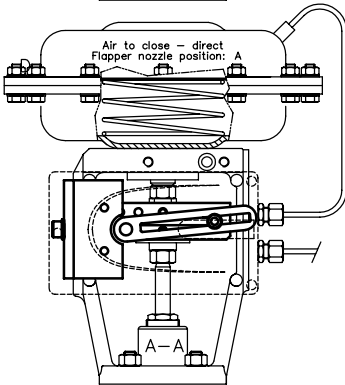
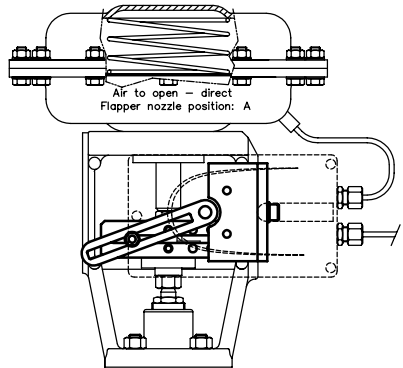
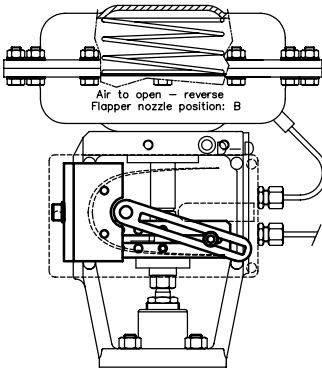

Connections

Air:

- Port S Supply air
- Port C+ Connection to actuator
- Port I_p Pneumatic input signal
(external I/P)



Electrical connection

- Port I_E Electric input signal

Data for air and electrical connections, see section Technical Data on page 20.

Dimensions

- Air connections: 1/4" NPT alt. G 1/4"
- Electrical connection: M20 x 1.5 alt. NPT 1/2"

Loctite 577 or equivalent is recommended as a sealant.

Direct / Reverse function

It is simple to adapt the positioner for direct or reverse function. Unscrew the flapper valve nozzle and reverse it, and change the mounting on the actuator. See figure page 12.

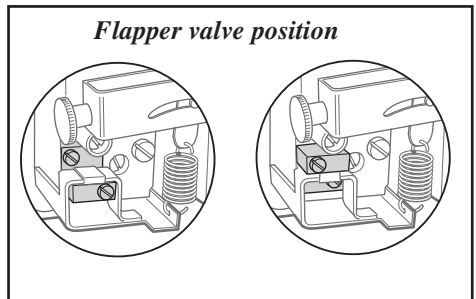

Single action positioner

Actuator with closing spring, flapper nozzle set for reverse function

When the signal from the I/P unit increases, the pressure C+ to the actuator is increased. The valve stem moves upwards.

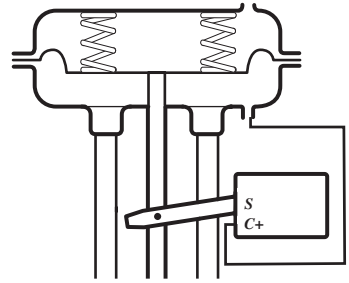
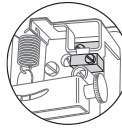

Actuator with closing spring, flapper nozzle set for direct function

When the signal from the I/P unit increases, the pressure C+ to the actuator is reduced. The spring forces move the valve stem downwards.

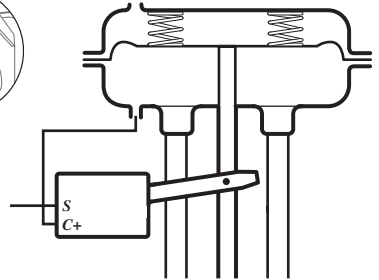
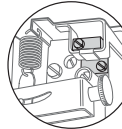

Actuator with opening spring, flapper nozzle set for reverse function

When the signal from the I/P unit increases, the pressure C+ to the actuator is increased. The valve stem moves downwards.

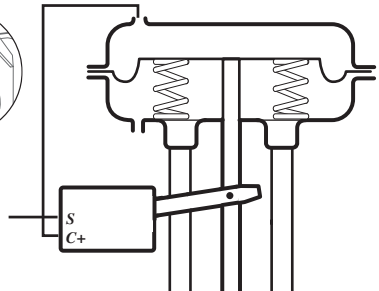
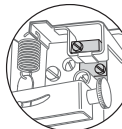

Actuator with opening spring, flapper nozzle set for direct function

When the signal from the I/P unit increases, the pressure C+ to the actuator is reduced. The spring forces move the valve stem upwards.

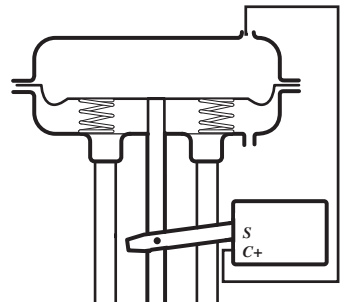
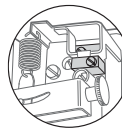

Control drawing

REV	MODIFICATION	DATE	MOD.BY
1	Redesigned	080825	MRn

UNCLASSIFIED AREA

HAZARDEOUS AREA

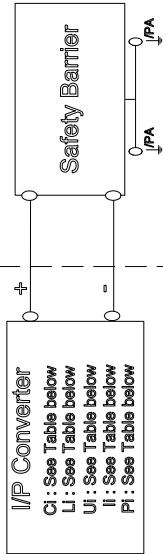

ELECTRICAL PARAMETERS:

Temp. Class	Ambient Temp.	li	Ui	Pi	Ci	Li
T6	-55°C to +60°C	50 mA	42.5 V	531mW	Negligible	Negligible
T6	-55°C to +55°C	60 mA	38.8 V	582mW	Negligible	Negligible
T5	-55°C to +70°C	60 mA	38.8 V	582mW	Negligible	Negligible
T4	-55°C to +85°C	60 mA	38.8 V	582mW	Negligible	Negligible
T5	-55°C to +55°C	100mA	30 V	750mW	Negligible	Negligible
T4	-55°C to +85°C	100mA	30 V	750mW	Negligible	Negligible
T5	-55°C to +45°C	120mA	28 V	840mW	Negligible	Negligible
T4	-55°C to +80°C	120mA	28 V	840mW	Negligible	Negligible
T4	-55°C to +70°C	50 mA	28.5 V	956mW	Negligible	Negligible

II 2G Ex ia IIC T4–T6

The I/P converter has to be installed in an enclosure that satisfy the following clauses:

- Complees with "electrostatic charge" requirements in EN 60079–0, clause 7.3
- A suitable degree of protection minimum IP20 acc. to clause 6.1 in EN 60079–11
- Shall not contain, by mass, more than 7.5% in total of magnesium, acc. to clause 8.1 in EN 60079–0
- Shall withstand dielectric strength test with 500V AC for 1 minute acc. to clause 6.3.12 in EN60079–11

PART NO./PCB TABLE TOL.	DESCRIPTION UNSPECIFIED TOLERANCES ACCORDING TO:	MATERIAL	DIMENSION	ANNOTATION
		SURFACE	PROJECTION EUROPA	
Control Drawing				
FLOWERVE PMV/Positioner		PMV Positioner I/P Converter	DRW BY KEM	DATE 070705
PALMSTIERNA INTERNATIONAL AB			DRAWING NO.	IP-653
KORTA GATAN 9 SE-171 54 SÖLNA SWEDEN - Tel:+46(0)8 555 106 00.-Fax:+46(0)8 555 106 01 - www.pmv.se				

This document must not be copied without our written permission and the contents thereof must not be imparted to a third party nor be used for any unauthorized purpose. Contravenion will be prosecuted.

7. Adjustments

Gain

Default settings

The positioner is supplied from the factory with default settings.

If the settings have been changed, the default settings can be reset as follows:

- Apply an input signal equivalent to maximum stroke (100%).
- Screw in (clockwise) the setting screw **A** for gain to its bottom position.
- Unscrew (counter clockwise) the same screw until the actuator is at max. stroke and then a further 1/4 of a turn.
- Press on the flapper nozzle lightly (see arrow) to ensure that it is sealing properly.
- Adjust the input signal to approx. 50%. If resonance occurs, turn the setting screw **A** counter clockwise a little more. The adjusting screw for damping **B** can also be screwed in a little if necessary. However, this will slow down the actuator movements.

Setting the zero position and span

If the zero position and span have been changed, adjust them as follows:

- Apply an input signal equivalent to the zero position.
- Turn the setting screw **C** for zero position until the actuator is at its zero position.
- Apply the maximum input signal.
- Turn the adjusting screw **D** for range until the actuator moves to max. stroke
- Adjust the input signal again to minimum and check the zero position.

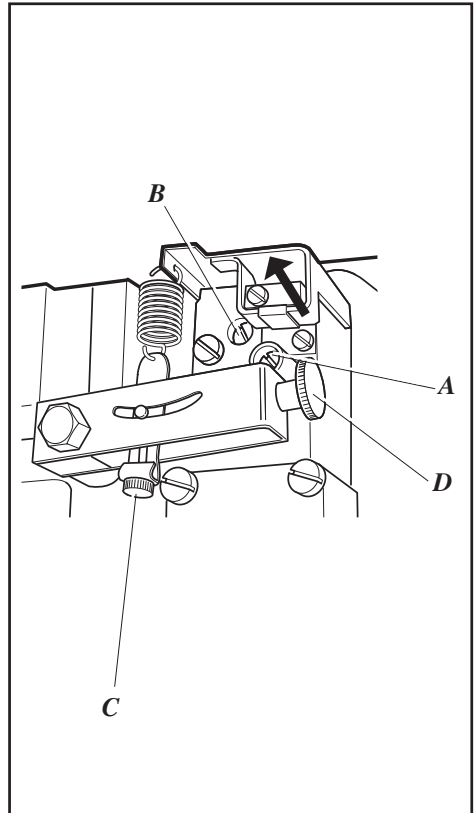

8. Maintenance/service

When service or rebuilding is required, it may be necessary to remove and refit various parts of the positioner. This is described on the following pages.

Cleanliness is essential when working with the positioner. Contamination in the air ducts will lead to operational disturbances. Do not disassemble the unit further than that described here.

Do not take the valve block apart because its function will be impaired.

Do not remove any screws other than those described here.

Valve block

The valve block is mounted on the base with three screws. It is sealed against the air ducts in the base with O-rings.

Remove the valve block as follows:

- Remove the spring from its attachment hole A in the balance arm.
- Unscrew the screws holding the block assy.
- Lift the lower edge of the valve block and pull it away from the base in the direction of the arrow in the figure.
- Check all the O-rings on the rear side of the valve block and replace if necessary.
- Refit in the reverse order.

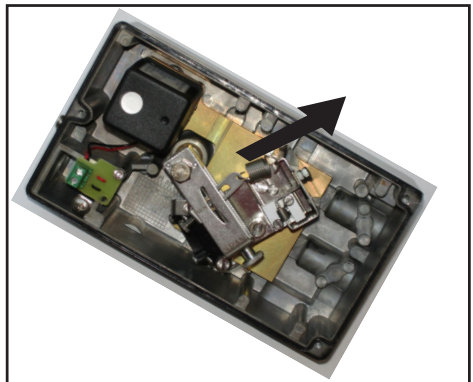
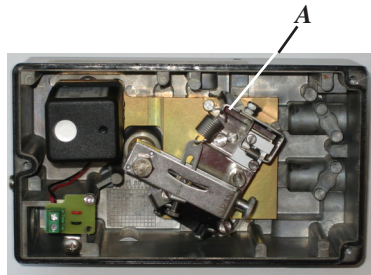

Flapper nozzle

The flapper valve holder can be mounted in two different ways, depending on the required function. This is described on page 11. Change the function or replace the O-rings as follows:

- Unscrew the screws **C** and **D** and remove the holder **E**. Check both the O-rings and replace them if necessary.
- Replace the holder in the desired position and tighten the screws.

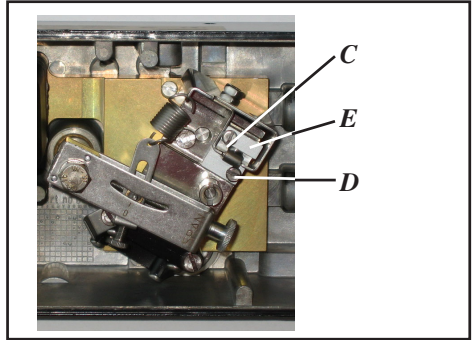

Gain screw

The sleeve **F** can be unscrewed to replace the O-ring **G**. Let the adjusting screw remain in the sleeve.

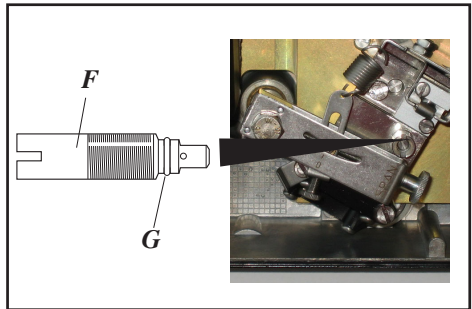

Integral I/P converter

The I/P converter can be removed if it is necessary to replace it, to replace the O-rings, or to rebuild the positioner.

- First unscrew the two screws **H** that hold the terminal block. Release part of the rubber seal so that the cables to the terminal block can be pulled free from the grommet and the terminal block can be pulled through.
- Remove the I/P unit with its cable and terminal block.
- Replace the O-rings if necessary and refit the I/P unit or the rebuilding parts.

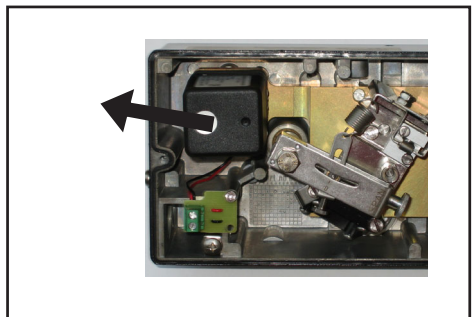
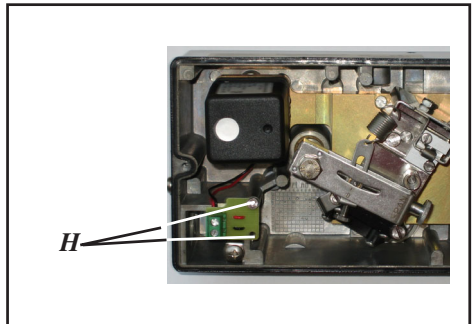

Feedback arm / Spindle

The feedback arm is mounted on the spindle with a friction clutch comprising several disc springs. Remove the feedback arm/spindle as follows:

- Remove the circlip **J**, the washer **K** behind it, and the O-ring **L**.
- Release the spring from its upper attachment **M**.
- Pull out the spindle with the feedback arm.

Remove the feedback arm as follows:

- Clamp the spindle in such a way that its surfaces cannot be damaged.
- Undo the bolt **N** and remove the feedback arm and the seven disc springs **O**.
- Refit in the reverse order. The disc springs **O** must be fitted in the way shown in the figure below. Lubricate the O-ring **L** with silicone grease.
- Check whether there is any play on the spindle. If so, replace the teflon bushes **P**.

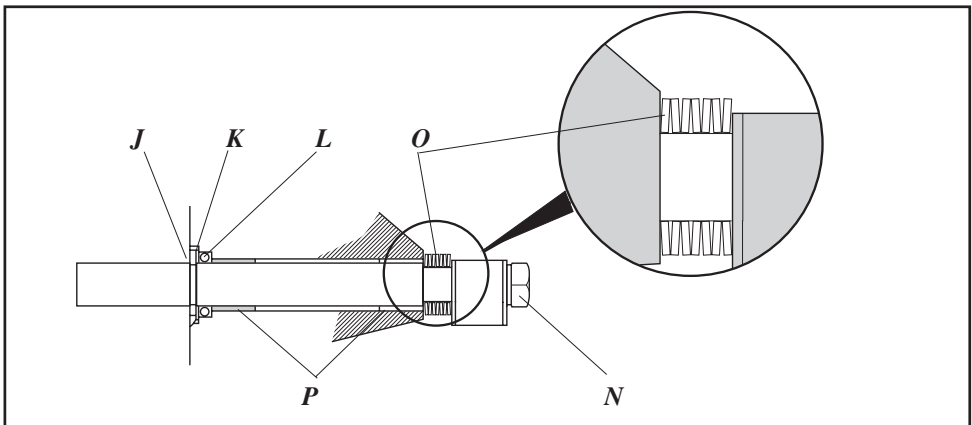
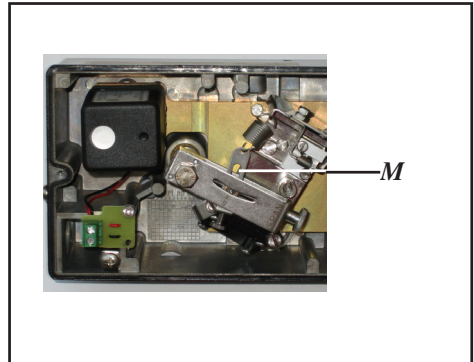
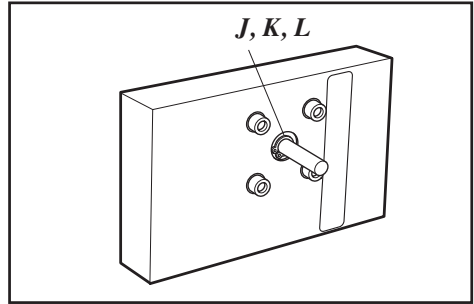

9. Trouble shooting

Fault symptom	Action
<p>Change in input signal to positioner does not affect actuator position.</p>	<ul style="list-style-type: none"> • Check air supply pressure and connection between positioner and actuator. • Check input signal to positioner. • Check output signal from I/P converter. • Check mounting and connections of positioner and actuator. • Check function of diaphragm block.
<p>Change in input signal to positioner makes actuator move to its end position.</p>	<ul style="list-style-type: none"> • Check input signal. • Check mounting and connections of positioner and actuator.
<p>Inaccurate positioning.</p>	<ul style="list-style-type: none"> • Uneven air supply pressure. • Uneven input signal. • Wrong size of actuator being used. • High friction in actuator/valve package. • Excess play in actuator/valve package. • Excess play in mounting of positioner on actuator. • Defect or leaking diaphragm block.

10. Technical data

Common data

Repeatability	<0,3%
Air delivery Supply at 600 kPa	125 nl/min
Air delivery Exhaust at 600 kPa	125 nl/min
Air supply pressure range	140-600kPa
Gain % / % acc. to ISA S75	5 to 30 %/%
Temperature range	-40°C to +85°C
Temperature sensitivity	< 0.4% per 10°C
Stroke length	6 - 60 mm, option 3 mm

Other data

P3

Linearity	<±1%
Hysteresis + Deadband	<0.5%
Deadband	<0.15%
Air consumption (depending on gain setting)	2-8 nl/min
Supply pressure sensitivity	<0.20%
Input signal	0.2 - 1 bar (3 - 15 psi)

EP3

Linearity	<±1.5%
Hysteresis + Deadband	<1%
Deadband	<0.2%
Air consumption (depending on gain setting)	4-10 nl/min
Supply pressure sensitivity	<0.3%
Input signal	4 - 20 mA

EP3EX

Linearity	<±1.5%
Hysteresis + Deadband	<1%
Deadband	<0.2%
Air consumption (depending on gain setting)	4-10 nl/min
Supply pressure sensitivity	<0.3%
Input signal	4 - 20 mA

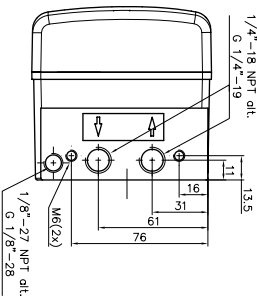
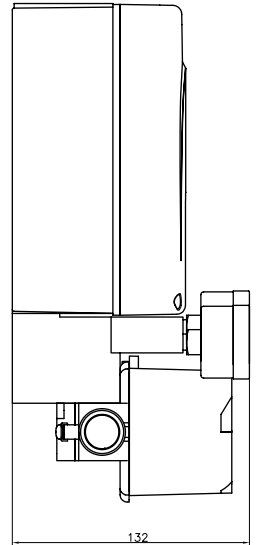
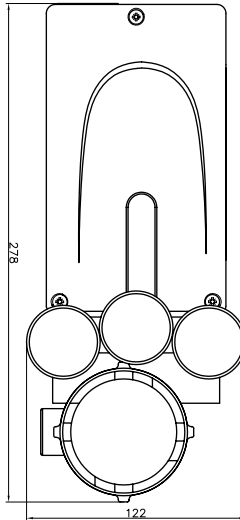
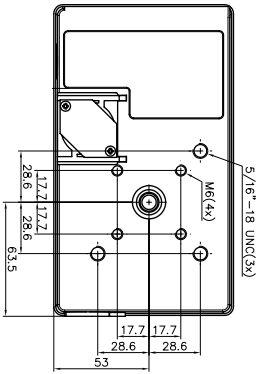
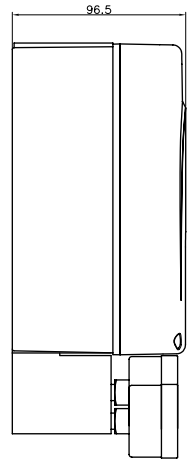
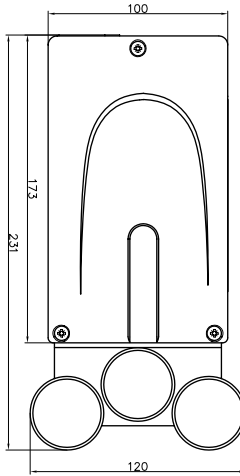
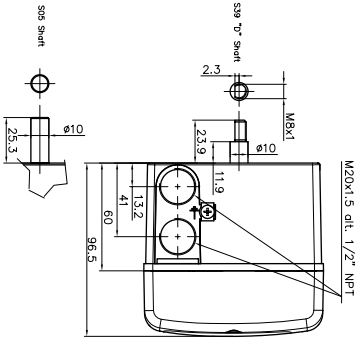

11. Spare Parts List

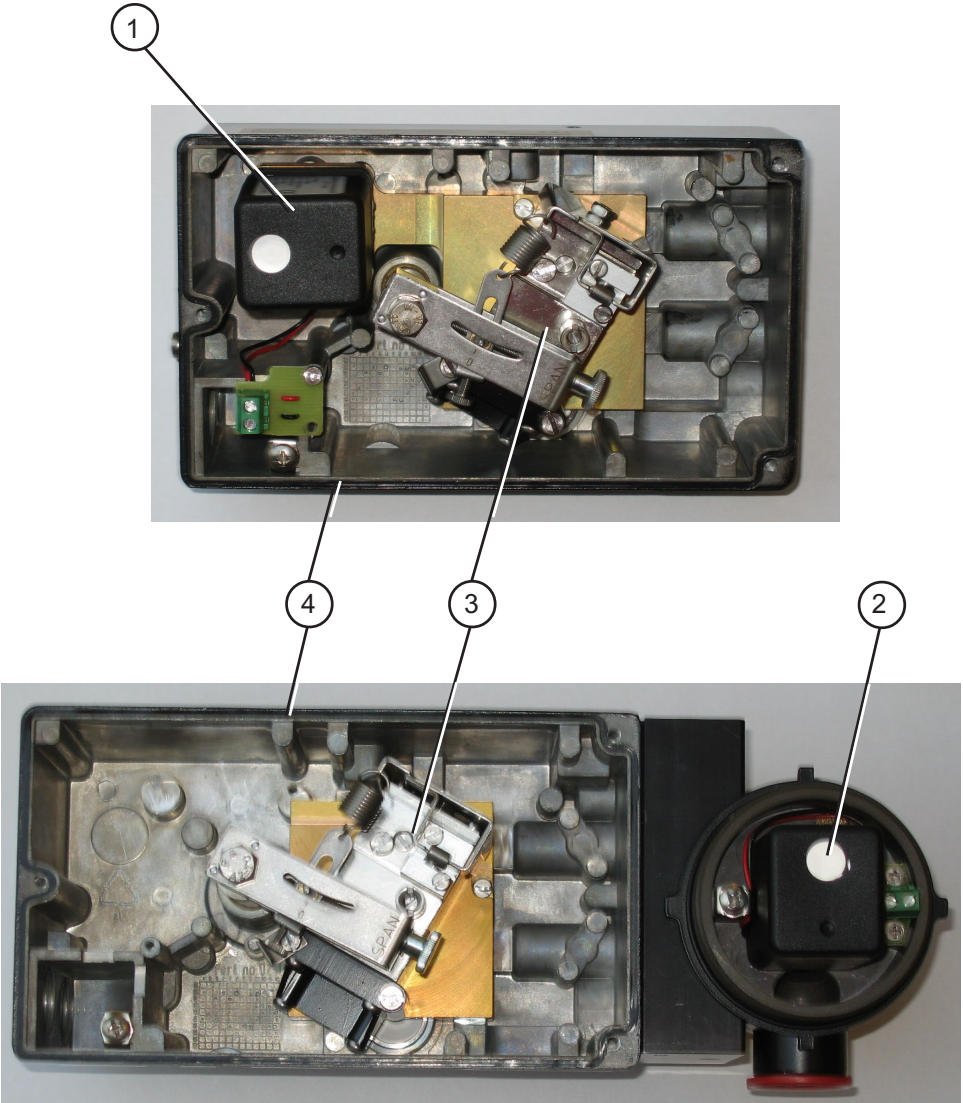

Pos.	Part no.	Description
1	E5-STD	I/P Converter general purpose
1	E5-IS	I/P Converter intrinsically safe
2	E3-EX	I/P Converter explosion proof, incl bracket
3	P3-SP15	Air relay module, single acting
4	7-SP25B	Cover incl screws



Palmstierna International AB

Korta Gatan 9
SE-171 54 Solna
SWEDEN
Tel: +46 (0) 8 555 106 00
Fax: +46 (0) 8 555 106 01
E-mail: infopmv@flowserve.com

www.pmv.nu

Germany

Flowserve
Sperberweg 16
D-41468 Neuss
GERMANY
Tel: +49 (0) 2131 795 74 80
Fax: +49 (0) 2131 795 74 99
E-mail: pmvgermany@flowserve.com

UK

Flowserve
Abex Road
Newbury, Berkshire, RG14 5EY
UK
Tel: +44 (0) 1635 46 999
Fax: +44 (0) 1635 36 034
E-mail: pmvukinfo@flowserve.com

Scandinavia

Palmstiernas Svenska AB
Box 21
663 21 Skoghall
Sweden
Tel: +46 (0)54 52 14 70
Fax: +46 (0)54 52 14 42
e-mail: info@palmstiernas.se

Italy

Flowserve Spa
Via Prealpi, 30
20032 Cormano (Milano)
ITALY
Tel: +39 (0) 2 663 251
Fax: +39 (0) 2 615 18 63
E-mail: infoitaly@flowserve.com

USA, Mexico

PMV-USA
1440 Lake Front Circle, Unit 160
The Woodlands, TX 77380
USA
Tel: +1 281 292 7500
Fax: +1 281 292 7760
E-mail: pmvusa@flowserve.com

Canada

Cancoppas Limited
2595 Dunwin Drive, Unit 2
Mississauga, Ont L5L 3N9
CANADA
Tel: +1 905 569 6246
Fax: +1 905 569 6244
E-mail: controls@cancoppas.com

Asia Pacific Headquarters

Flowserve Pte Ltd.
No. 12 Tuas Avenue 20
REPUBLIC OF SINGAPORE 638824
Tel: +65 (0) 687 98900
Fax: +65 (0) 686 24940
E-mail: fcdasiaprocess@flowserve.com

South Africa

Flowserve
Unit 1, 12 Director Road
Spartan Ext. 2
1613 Kempton Park, Gauteng
SOUTH AFRICA
Tel: +27 (0) 11 397 3150
Fax: +27 (0) 11 397 5300

The Netherlands

Flowserve Flow Control Benelux
B.V
Postbus 1501
4700 Roosendaal
THE NETHERLANDS
Tel: + 31 (0)165 598898
Fax: + 31 (0)165 555670

China

Flowserve
Hanwei Building
No. 7 Guanghua Road
Chao Yang District
100004 Beijing
CHINA
Tel: +86 (10) 6561 1900
Fax: +86 (10) 6561 1899