



Valtek Spring Cylinder Linear Actuators



Experience In Motion



Valtek Spring Cylinder Linear Actuator

Flowserve spring cylinder linear actuators are powerful, compact, high-performance pneumatic actuators that provide solid throttling or on-off operation for automatic control valves. The positioner supplies air to both sides of the piston, providing stiff, precise movement and high-frequency response and quick stroke speeds. The robust,

flexible design allows a wide range of accessories, quick maintenance in a small lightweight package. A selection of high thrust springs provide reliable fail-safe operation. The VL-UHC actuator is particularly well suited for applications where high numbers of full stroke cycles are required

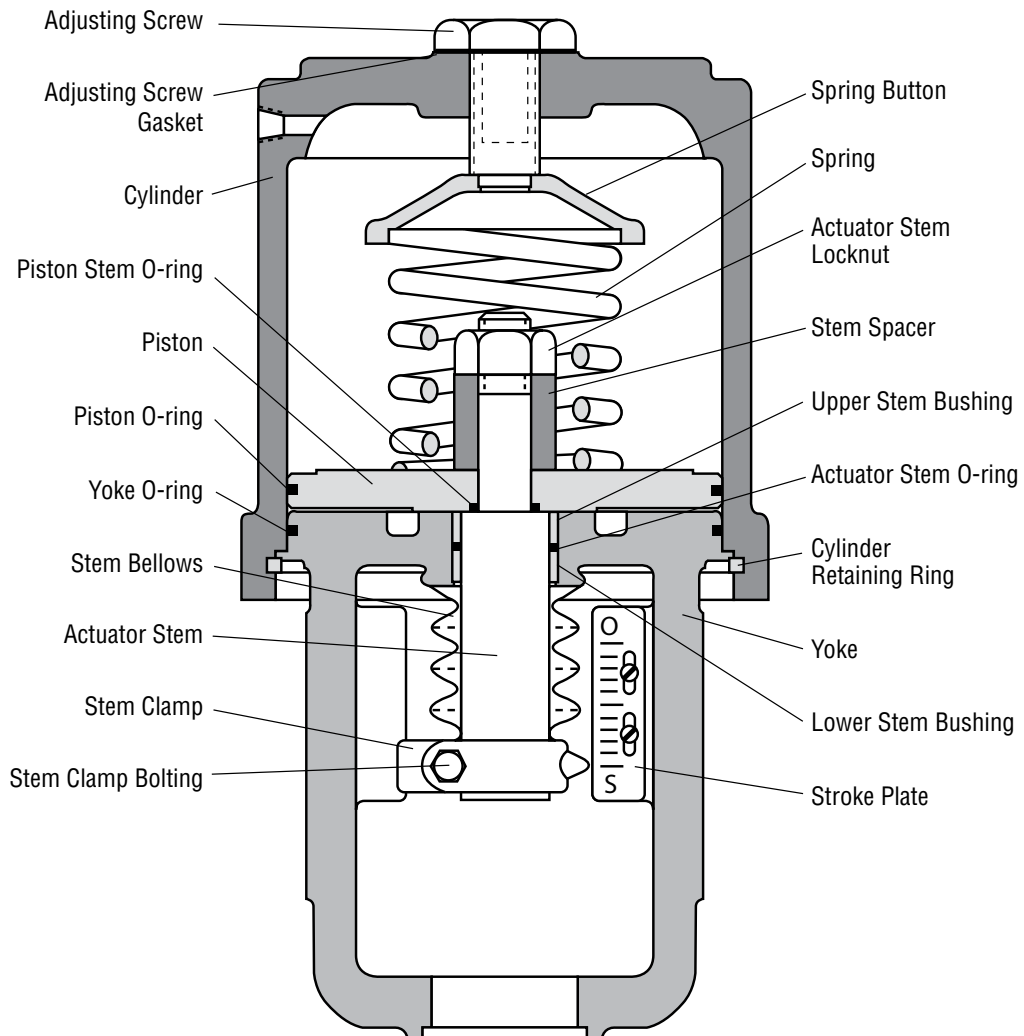



Features and Benefits

Important features and advantages of the Flowserve Valtek spring cylinder linear actuator include:

Features	Advantages
Multiple Positioners and Controllers	A variety of positioner/controller options makes the spring cylinder actuator ideal for a variety of control requirements.
High Frequency Response	Double-acting configuration responds quickly to signal changes.
Dynamic Positioning Accuracy	Supply pressure is modulated to both sides of piston for stiff, precise actuator operation; small air volume between the piston and the bottom of the cylinder provides powerful pneumatic stiffness, allowing a high pressure drop—without plug slamming.
Low Air Consumption	Cylinder design uses less supply air than comparable diaphragm actuators.
High Thrust Capability	150 psi (10.3 Bar) operating pressure allows substantially higher thrust capabilities than comparable diaphragm actuators. Higher thrust allows tighter valve shutoff.
Longer Stroke	Longer strokes provide better process control. Size 25 spring cylinder linear actuators have a 1½-inch (38 mm) stroke, in contrast to a ¾-inch (19 mm) stroke on a comparable linear diaphragm actuator. Larger actuators have similar comparisons; stroke lengths are available up to 24 inches.
Fail-Safe Spring	Internal spring provides fail-safe operation in the event of air system failure. Spring bench set is not required.
Compact and Light-weight	For easier installation and maintenance, spring cylinder linear actuators are substantially lighter and more compact than comparable linear diaphragm actuators.
Simple Maintenance	Periodic maintenance is easy to perform since the spring cylinder actuator only requires the removal of three parts to access all internal parts.
Durable Components	High-quality materials require little maintenance. There is no diaphragm to rupture.
Wide Range of Sizes	Standard actuator sizes 25, 50 and 100 will handle thrust requirements for over 95 percent of process applications; larger sizes through size 600 are available for special applications.
Fewer Parts	Spring cylinder linear actuators have one-third the number of parts as diaphragm linear actuators; wear parts cost 10 percent of those for diaphragms, and less inventory is required to maintain actuators.
Field Reversible	Failure mode is easily reversed without additional parts. Reduces inventory costs.
No Pressure Regulator Required	Cylinder actuators easily handle air supplies up to 150 psi (10.3 Bar) without a pressure regulator and can be operated with as little as 30 psi (2.1 Bar)*.

* Operating pressure on some sizes is limited because of valve sizes.

VL Series

The VL series is the standard set of actuators for Valtek control valves, providing precise control and reliable performance. With decades of experience and reliability, VL actuators have been known to be in service for over 30 years.

Providing maximum thrust from a compact lightweight package, the VL cylinder has set the industry standard for two generations.

Features and Benefits

Feature	Advantage
Wide Range of Options	A variety of options and accessories allow the VL cylinder to fit into almost any application requiring high thrust and low maintenance.
Compact and Lightweight	Using Aluminum cylinder construction, the VL cylinder is exceptionally compact and lightweight.
Simple Maintenance	Periodic maintenance is easy to perform. VL spring cylinder actuators only requires the removal of two parts to access all internal parts.
Simple Parts	Using standard O-rings for both static and dynamic seals, the VL cylinder actuator soft goods are lower cost and easier to find.

Materials of Construction

Part	Material
Yoke	Phosphated, Painted Ductile Iron
Yoke Clamp	Stainless Steel
Yoke Clamp Bolts	Zinc Plated Steel
Stem Clamp*	Phosphated, Painted Ductile Iron
Cylinder Retaining Ring	Zinc Plated Steel
Actuator Stem	416 Stainless Steel
Stem Spacer	Aluminum
Actuator Stem Lock Nut	Zinc Plated Steel
O-Rings	Buna-N
Spring	Alloy Steel
Spring Button	Painted Steel
Adjusting Screw	Zinc Plated Steel
Piston	Anodized Aluminum
Bushings	Bronze, Oilite
Cylinder	Painted Anodized Aluminum

*Stainless Steel material on 25 and 50 square inch

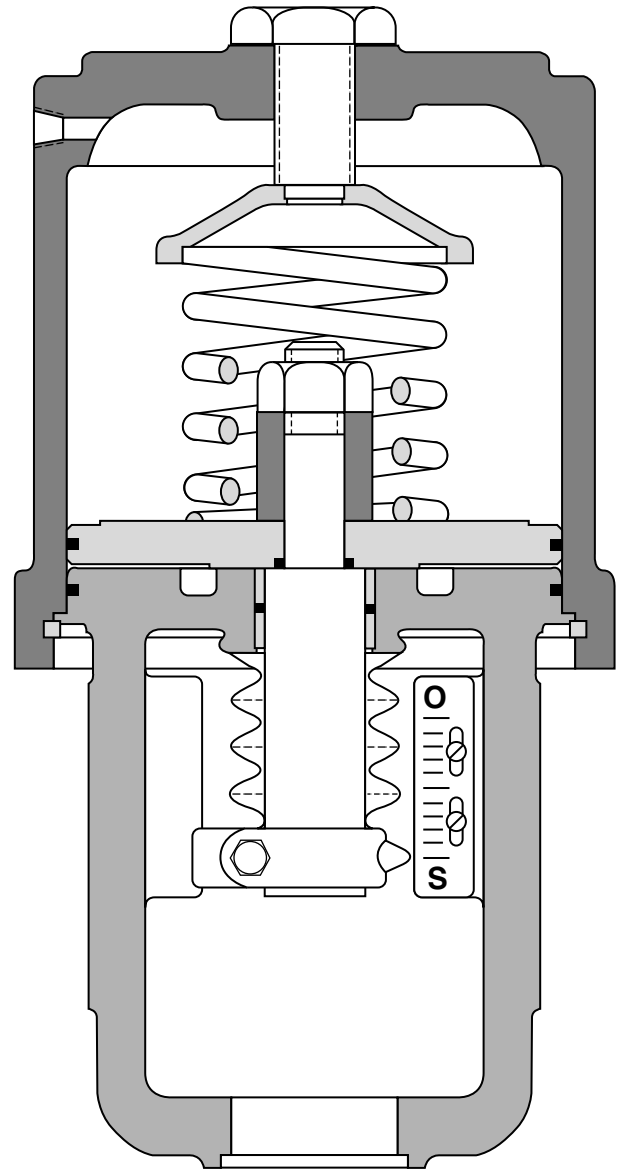

VL-C Series

For applications where aluminum materials are not acceptable, Flowserve offers the compact, lightweight and high thrust of the VL-C carbon steel spring cylinder linear actuator. Offering identical springs and all the advantages of VL actuators, the VL-C actuator replaces all aluminum parts with carbon steel.

Offered in two styles, the size 25 and 50 square inch actuators use deep drawn cylinders while the size 100, 150, 200, 300 and 400 offers tie rod construction.

Materials of Construction

Part	Material	
	Size 25 and 50	Size 100 and Larger
Yoke	Phosphated, Painted Ductile Iron	Phosphated, Painted Ductile Iron
Yoke Clamp	Stainless Steel	Stainless Steel
Yoke Clamp Bolts	Zinc Plated Steel	Zinc Plated Steel
Stem Clamp*	Stainless Steel	Phosphated, Painted Ductile Iron
Cylinder Retaining Ring	Zinc Plated Steel	—
Tie Rods and Nuts	—	Carbon Steel
Actuator Stem	416 Stainless Steel	416 Stainless Steel
Stem Spacer	Carbon Steel	Carbon Steel
Actuator Stem Lock Nut	Zinc Plated Steel	Zinc Plated Steel
O-Rings	Buna-N	Buna-N
Quad Seals	—	Buna-N
Spring	Alloy Steel	Alloy Steel
Spring Button	Carbon Steel	Carbon Steel
Adjusting Screw	Zinc Plated Steel	Zinc Plated Steel
Piston	Carbon Steel	Carbon Steel
Bushings	Bronze, Oilite	Bronze, Oilite
Cylinder	Zinc Plated, Painted Carbon Steel	Painted Carbon Steel
End Cap	—	Painted Carbon Steel

*Stainless steel material on 25 and 50 square inch.

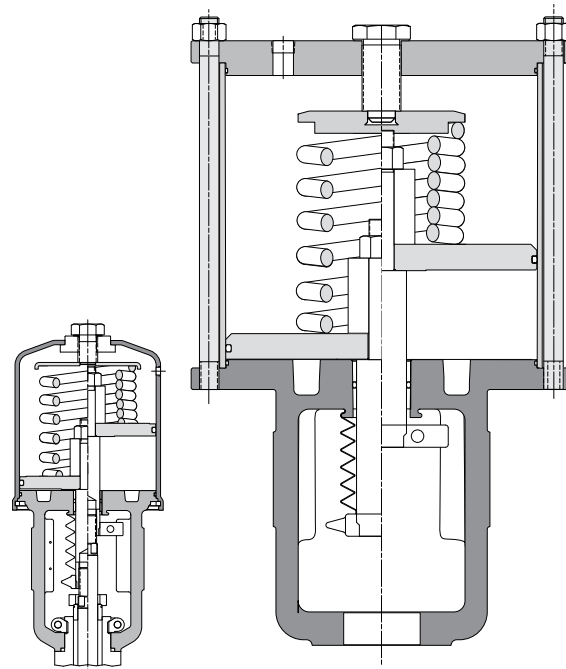

Features and Benefits

Feature	Advantage
Carbon Steel Construction	Replaces all aluminum parts with carbon steel.
Simple maintenance	Periodic maintenance is easy to perform. VL-C spring cylinder actuator sizes 25 and 50 only requires the removal of two parts to access all internal parts.
Simple Parts	Using standard O-rings for both static and dynamic seals, the VL cylinder actuator soft goods are lower cost and easier to find.

VL-UHC Series

For applications where ultra high cycle (UHC) life is needed, Flowserve offers the exceptionally long cycle life of the VL-UHC series actuators. By adding and modifying several parts used in the standard VL series actuator, the VL-UHC gains a cycle life previously thought unattainable. The VL-UHC actuator is particularly well suited for applications where high numbers of full stroke cycles are required.

Features and Benefits

Feature	Advantage
Life Cycles	Expected lifespan of up to 2 million full stroke cycles with periodic soft goods replacement.
Dynamic Quad Seals	All dynamic seals are quad seal design. This provides better lubrication and much longer life.
Plug Stem Jam Nut	Providing better alignment of the actuator stem and plug stem, the jam nut lengthens the life span of the bushings.
Same Simple Maintenance	Periodic maintenance is easy to perform. VL-UHC spring cylinder actuator only requires the removal of two parts to access all internal parts.
Recessed Adjusting Screw O-ring	Providing better tolerance control and sealing, the recessed O-ring adjusting screw seal lengthens the life of the actuator.
Thrust Bearing for the Spring	Thrust bearings prevent windup on the spring, lowering the stresses in the spring and giving it longer life.
Special Springs	Special springs with stronger materials and better finishes provide exceptionally long life spans.

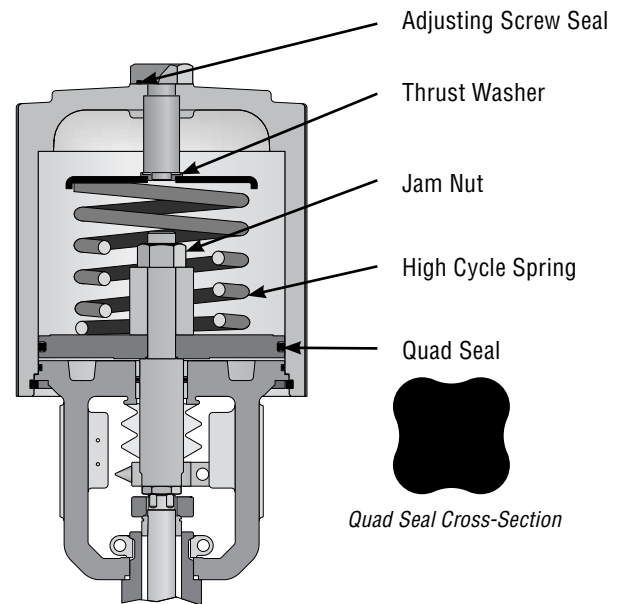

Materials of Construction

Part	Material
Yoke	Phosphated, Painted Ductile Iron
Yoke Clamp	Stainless Steel
Yoke Clamp Bolts	Zinc Plated Steel
Stem Clamp*	Phosphated, Painted Ductile Iron
Cylinder Retaining Ring	Zinc Plated Steel
Actuator Stem	416 Stainless Steel
Stem Spacer	Aluminum
Actuator Stem Lock Nut	Zinc Plated Steel
O-Rings	Buna-N
Quad Seals	Buna-N
Spring	Alloy Steel
Spring Button	Painted Steel
Adjusting Screw	Zinc Plated Steel
Piston	Anodized Aluminum
Bushings	Bronze, Oilite
Jam Nut	Zinc Plated Steel
Thrust Bearing	Delrin
Cylinder	Painted Anodized Aluminum

*Stainless Steel material on 25 and 50 square inch

VL-ES Series

Materials of Construction

Part	Material
Yoke	Phosphated, Painted Ductile Iron
Yoke Clamp	Stainless Steel
Yoke Clamp Bolts	Zinc Plated Steel
Stem Clamp	Phosphated, Painted Ductile Iron
Tie Rods and Nuts	Carbon Steel
Actuator Stem	416 Stainless Steel
Spring Connecting Rod	416 Stainless Steel
Actuator Stem Lock Nut	Zinc Plated Steel
O-Rings	Buna-N
Quad Seals	Buna-N
Spring	Alloy Steel
Spring Housing	Painted Carbon Steel
Spring Buttons	Carbon Steel
Spring Cap Bolting	Zinc Plated Steel
Piston	Anodized Aluminum
Bushings	Bronze, Oilite
Thrust Bearing	Delrin
Cylinder	Painted Carbon Steel
End Cap	Painted Carbon Steel

Features and Benefits

Feature	Advantage
Life Cycles	Expected lifespan of up to 2 million cycles!
Dynamic Quad Seals	All dynamic seals are quad seal design. This provides better lubrication and much longer life.
Plug Stem Jam Nut	Providing better alignment of the actuator stem and plug stem, the jam nut lengthens the life span of the bushings.
Same Simple Maintenance	Periodic maintenance is easy to perform. VL-UHC spring cylinder actuator only requires the removal of two parts to access all internal parts.
Thrust Bearing for the Spring	Thrust bearings prevent windup on the spring, lowering the stresses in the spring and giving it longer life.
Special Springs	Special springs with stronger materials and better finishes provide exceptionally long life spans.

For applications where longer strokes or unusually high spring thrusts are required, Flowserve offers the VL-ES series actuators. Using many of the same design concepts as the VL-C, the VL-ES offers external spring cans. This allows for extra long springs which provide longer stroke lengths and higher forces.

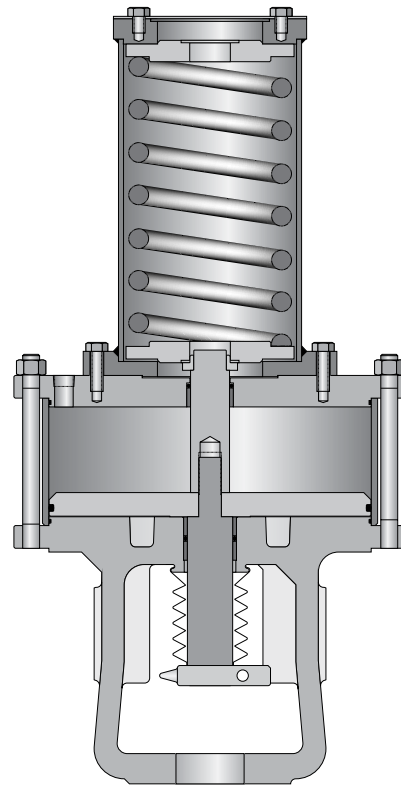



Common Positioners and Control Software



Logix 3000 Series Digital Positioners



XL and Beta Series Analog Positioners



ValveSight Diagnostic and Preventative Maintenance Software



Logix 500 Series Digital Positioners



Auxiliary Equipment

Positioners

- XL pneumatic or electro-pneumatic positioner
- Beta pneumatic or electro-pneumatic positioner
- Logix 500 digital positioner series
 - HART
- Logix 3000 digital positioner series
 - HART
 - FOUNDATION Fieldbus
- StarPac digital flow measurement and control series

Air Filters A variety of air filters are available.

PosPac Position transmitter feeds back a 4-20 mA signal on position.

Flow Booster For faster stroke times.

Limit Switches

Solenoids

Optional Configurations

Many optional configurations are available. Among the most common are:

- Failsafe external volume tank systems
- Failsafe lock up systems
- Solenoid override systems

Table I: Typical Actuator Stroking Times

Actuator Size	Time for Maximum Stroke (seconds)*		Stroke	
	0.25" Tubing	0.375" Tubing	in.	mm
25	1.2	1.0	1.5	38
50	3.8	3.0	3	76
100	11.5	9.0	4	102
200	—	15.4	4	102
300	—	24.1	4	102

Actuation pressure: 60 psi (4.1 Bar)

* Stroking time only

Table II: Actuator Stiffness

Percent Stroke	Stiffness (lb/in)	Stiffness (N/mm)
100	3441	603
75	4588	803
50	6882	1205
25	13763	2410
10	34408	6026
5	68816	12052

Note: 25 square inch actuator with 150 psi air supply and 1.5" stroke



Continuously Connected Handwheels

Continuously connected handwheels are highly versatile. They can be used to retract or extend the stem and act as either a high or low-limit stop. The simplified design makes it easy to place the handwheel in a neutral position for automatic operation of the actuator.

Side-Mounted Handwheel

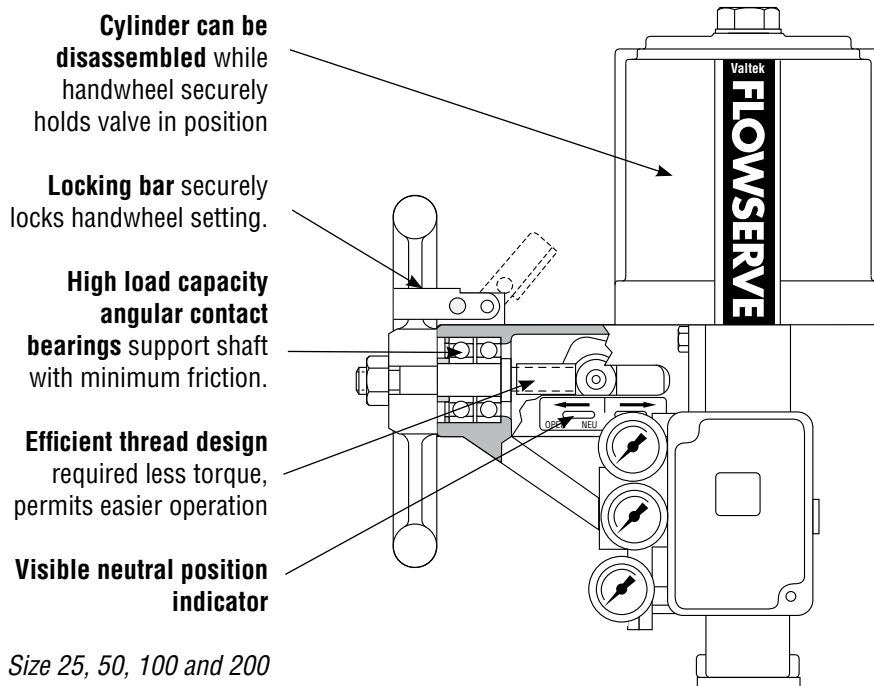



Top-Mounted Handwheel

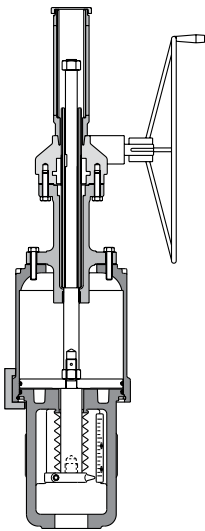

Push-Only Handwheel

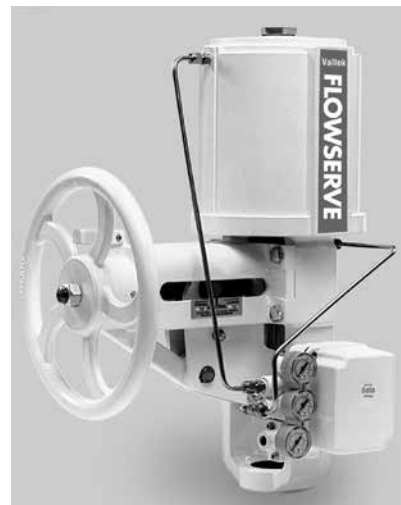
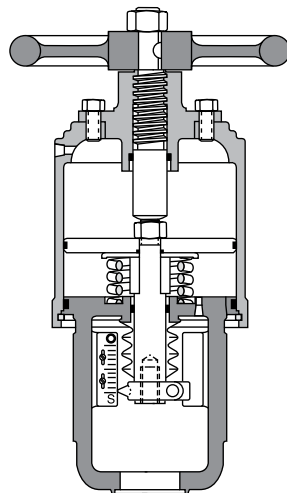

Side-mounted auxiliary handwheel on a size 25 Linear Actuator.



FCD VLENBR0002-00-AQ Printed in USA. August 2014. © 2014 Flowserve Corporation

To find your local Flowserve representative:

For more information about Flowserve Corporation, visit www.flowserve.com or call USA 1 800 225 6989

Flowserve Corporation has established industry leadership in the design and manufacture of its products. When properly selected, this Flowserve product is designed to perform its intended function safely during its useful life. However, the purchaser or user of Flowserve products should be aware that Flowserve products might be used in numerous applications under a wide variety of industrial service conditions. Although Flowserve can (and often does) provide general guidelines, it cannot provide specific data and warnings for all possible applications. The purchaser/user must therefore assume the ultimate responsibility for the proper sizing and selection, installation, operation, and maintenance of Flowserve products. The purchaser/user should read and understand the Installation Operation Maintenance (IOM) instructions included with the product, and train its employees and contractors in the safe use of Flowserve products in connection with the specific application.

While the information and specifications contained in this literature are believed to be accurate, they are supplied for informative purposes only and should not be considered certified or as a guarantee of satisfactory results by reliance thereon. Nothing contained herein is to be construed as a warranty or guarantee, express or implied, regarding any matter with respect to this product. Because Flowserve is continually improving and upgrading its product design, the specifications, dimensions and information contained herein are subject to change without notice. Should any question arise concerning these provisions, the purchaser/user should contact Flowserve Corporation at any one of its worldwide operations or offices.

© 2014 Flowserve Corporation, Irving, Texas, USA. Flowserve is a registered trademark of Flowserve Corporation.

USA

Flowserve Flow Control Division
1350 N. Mt. Springs Parkway
Springville, UT 84663
USA
Phone: +1 801 489 8611
Fax: +1 801 489 3719

Austria

Flowserve Control Valves GmbH
Kasernengasse 6
9500 Villach
Austria
Phone: 43 (0) 4242 41 181 0
Fax: 43 (0) 4242 41181 50
France
Flowserve France S.A.S.
BP 60 63307 Thiers Cedex
France
Phone: 33 4738 04266
Fax: 33 4738 01424

India

Flowserve India Controls Pvt Ltd.
Plot # 4, 1A, Road #8 EPIP
Whitefield
Bangalore, Karnataka, 560066
India
Phone: 91 80 40146200
Fax: 91 80 28410286

China

Flowserve Fluid Motion and
Control (Suzhou) Co., Ltd.
No. 35, Baiyu Road
Suzhou Industrial Park, Suzhou
Jiangsu Province, P.R. 215021
China
Phone: 86 512 6288 8790
Fax: 86 512 6288 8736

Singapore

Flowserve Pte. Ltd.
12 Tuas Avenue 20
Republic of Singapore 638824
Phone: 65 6879 8900
Fax: 65 6862 4940

Saudi Arabia

Flowserve Abahsain Flow Control
Co., Ltd.
Makkah Road, Phase 4
Plot 10 & 12, 2nd Industrial City
Dammam, Kingdom of Saudi
Arabia
Phone: +966 3 857 3150 ext. 243
Fax: +966 3 857 4243